

HELLO PAUL

INSTRUCTION MANUAL PRETERM SIMULATOR PAUL 2.0



 [simcharacters.at](https://www.instagram.com/simcharacters.at)

 [HighEmotionSimulation](https://www.facebook.com/HighEmotionSimulation)

 [@SIMCHARACTERS](https://twitter.com/SIMCHARACTERS)

[simcharacters.com](https://www.simcharacters.com)

CONTENT

Introduction to Paul!	3	Paul´s Features in Detail - Circulation.....	36
Overview Features Paul 2.0.....	5	Palpable Pulses.....	36
Scope of delivery	6	Chest Compressions.....	37
Tube paint kit	8	Peripheral Accesses	38
Safety Precautions	10	Placement of an Umbilical Venous Catheter.....	39
Administration of drugs and fluids during scenarios ...	11	Replacing the Umbilical Cord.....	40
System Set-up.....	12	Paul´s Features in Detail - Auscultation	42
WIFI-Connection.....	12	Paul´s Features in Detail - Symptom Complexes	44
Control Laptop & Patient Monitor	15	Seesaw Breathing and Retractions - RDS.....	45
The Patient Simulator Paul	17	Seesaw Breathing - BPD.....	45
Using the Simulation Stethoscope	18	Necrotizing Entercolitis - NEC	46
Login to the Control Laptop.....	19	Abdominal Distention	47
Before you start	21	Costumization Pre-Sets	48
The User Interface (SIMCharacters GUI)	23	The Patient Monitor.....	53
Control Paul through the 3D Simulation.....	26	Configuration of the Patient Monitor.....	55
Paul´s Features in Detail – Breathing	28	Control of the Patient Monitor.....	57
Normal Breathing.....	28	Operation of the Patient Monitor	58
Changing Lung Compliance.....	29	Feedback Monitor	59
Pneumothorax	30	Scenario Design	63
Cyanosis and Hhyperoxia.....	31	Debriefing system	68
Paul´s Features in Detail - Ventilation	32	Care, Storage and Maintenance	70
Head Positioning.....	32	We care for your Paul!.....	71
Manual Ventilation	33	Remote Support	72
Intubation	34	Troubleshooting	74
Palpable Pulses.....	36	Specifications Paul 2.0	76



HIGH EMOTION SIMULATION

INTRODUCING PAUL 2.0!

We are delighted that you have decided to use Paul and appreciate the trust you have placed in us.

The SIMCharacters team would also like to support you in the period after the purchase of this simulation system. SIMCharacters regards itself as your partner for top-quality simulation training. We look forward to receiving your feedback about Paul and are available at any time to personally handle any questions, suggestions or complaints you may have.

This instruction manual is intended to help you set up and run Paul and also describes all of Paul's features in detail.

We wish you many successful training sessions with Paul!

Warm regards,

The SIMCharacters team



Elentári Tanja Nepomucky

HEAD OF SFX &
PRODUCT DESIGN



Michael Haller, MSc

HEAD OF RESEARCH &
DEVELOPMENT



Sara Ziegelbecker

HEAD OF SOFTWARE
ENGINEERING



Arjeta Fishta

TECHNICAL SUPPORT



Dr. Jens-Chr. Schwindt

CEO SIMCHARACTERS &
NEONATOLOGIST

SUPPORT

Email: support@simcharacters.com

Phone: +43 664 25 66 818

Fax: +43 1 581 20 945

PAUL ...

With a size of 35 cm and a weight of 1100g, Paul is an accurate recreation of a baby born preterm in the 27th week of gestation. He has been developed by experts in the fields of preterm medical care, special effects design and animatronics. His internal and external anatomy is a like-for-like copy of a preterm baby.

The highly realistic upper airways make it possible, for the first time, to conduct realistic training to provide care to preterm babies in all possible areas of specialization.

Since Paul has been developed based on a real preterm, please treat him with the same caution and care as you would treat a real preterm baby.



OVERVIEW FEATURES PAUL 2.0

PRETERM SIMULATOR

- Preterm gestational week 27+3
- Weight: 1100g
- Length: 35 cm
- Head Circumference: 26 cm
- Highly realistic external anatomy
- Real hair
- 3 hours of mobile battery use
- Battery indicator under the skin
- Ready-to-use (incl. control laptop, patient monitor, ...)

AIRWAY

- Highly realistic upper airway
- Oral and nasal intubation
- Ideal for training endotracheal intubation, LISA (MIST) and INSURE

NORMAL BREATHING

- Spontaneous breathing with respiratory rate variable between 0 and 100bpm
- Physiological lung with realistic values under mechanical ventilation

BREATHING PATHOLOGIES

- Infinitely variable lung compliance
- Inverted breathing
- Pathological respiration noises (grunting)
- Pneumothorax

CIRCULATION

- Silent palpable pulse on all four extremities and on the umbilical cord
- Chest compressions
- Insertion of peripheral vascular accesses in all four extremities (exchangeable)
- New and optimized connector for exchangeable umbilical cord

AUDIO EFFECTS

- Crying
- Grunting
- Amniotic fluid

STETHOSCOPE

- Optimized position-dependent auscultation of respiratory, heart and stomach sounds via bluetooth stethoscope

SENSORS

- Head position sensor
- Detection of the tube in the trachea or esophagus
- Detection of the tube depth
- Automatic collapse of the left lung if an endotracheal tube is inserted too deeply into the right main bronchus
- Effectiveness of chest compressions
- Detection of umbilical cord transection
- Detection of the umbilical venous catheter and the insertion depth

CONTROL LAPTOP

- Wi-Fi operated Manikin
- Inputs via touchscreen, keyboard and mouse
- Surface Laptop Studio with foldable screen for in-situ training

GRAPHICAL USER INTERFACE (GUI)

- 3D animation of the manikin within the GUI
- Real-time display of all physiological and pathological processes and therapeutic interventions (e.g. mask ventilation and intubation)
- Automatic transfer of events and manikin status to the debriefing interface
- Ability to add annotations via the debriefing interface

PRE-SETS

- User configuration and fine-tuning of limits for head position, optimal tidal volume, chest movement and strength of palpable pulses

FEEDBACK MONITOR

- Direct feedback for your trainees during orientation phase on head position, PEEP, PIP, tidal volumes, ventilation rate, depth- and position of endotracheal tube, and efficiency of chest compressions

PRECONFIGURED PATIENT MONITORS

- Easily switch between monitor types via the trainer monitor
- Dräger, Philips, Nellcor, GE
- User-defined configuration and use corresponding to the interface of the original monitor
- Touch-screen function
- Various monitor sizes
- Pre and post ductal saturation
- Endtidal CO₂ curve
- Motion artifacts in all curves

SCENARIO DESIGN

- Pre-programmed symptom complexes (RDS, BPD, NEC, Abdominal Distension, Apnea)
- Intuitive programming of scenarios through quick save function
- Easy access to factory settings and scenario progressions

CARE PROGRAM

- Guarantee extension & maintenance program: Extend your SIMCharacters standard warranty to two years for all parts and labor. The two-year program includes one general refurbishment of the simulator during the contractual term. The five-year program includes two general refurbishments. These refurbishments include a full check of all functions and preventative exchange of parts subject to wear and tear. The checks, maintenance work and repairs are performed by SIMCharacters. All shipping costs are covered by SIMCharacters. If necessary, we will provide you with a fully functional replacement system for the period of time that your system is being refurbished or repaired by SIMCharacters.
- 2 hour remote introduction and setup of Paul
- Free software updates

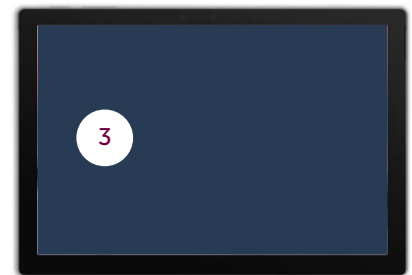
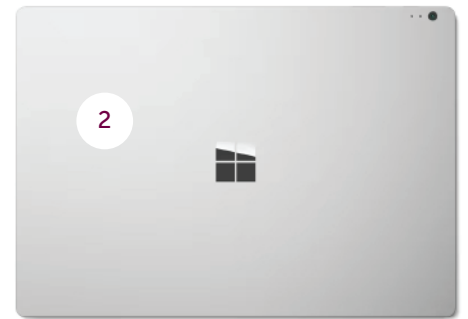
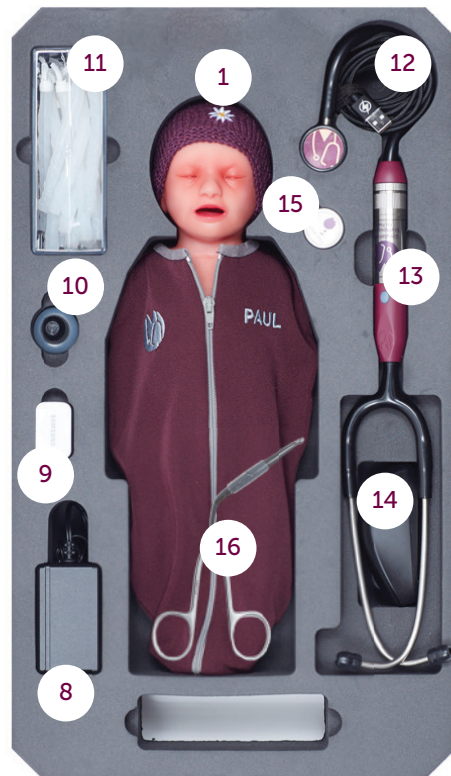

SCOPE OF DELIVERY

- 1 Preterm simulator – Paul
- 2 Simulator control laptop including pre-installed software (GUI)
- 3 Tablet PC incl. pre-installed vital monitor software
- 4 Charging pad
- 5 Power supply laptop
- 6 Power supply tablet
- 7 Router
- 8 Power supply router
- 9 Power supply Paul
- 10 SIMCharacters silicone oil
- 11 20 Umbilical cords
- 12 Charging cable Paul
- 13 SIMCharacters Stethoscope
- 14 Bluetooth Mouse
- 15 Magnet
- 16 Magill forceps

NOT SHOWN

Endotracheal tube
Belly button
Tube paint kit

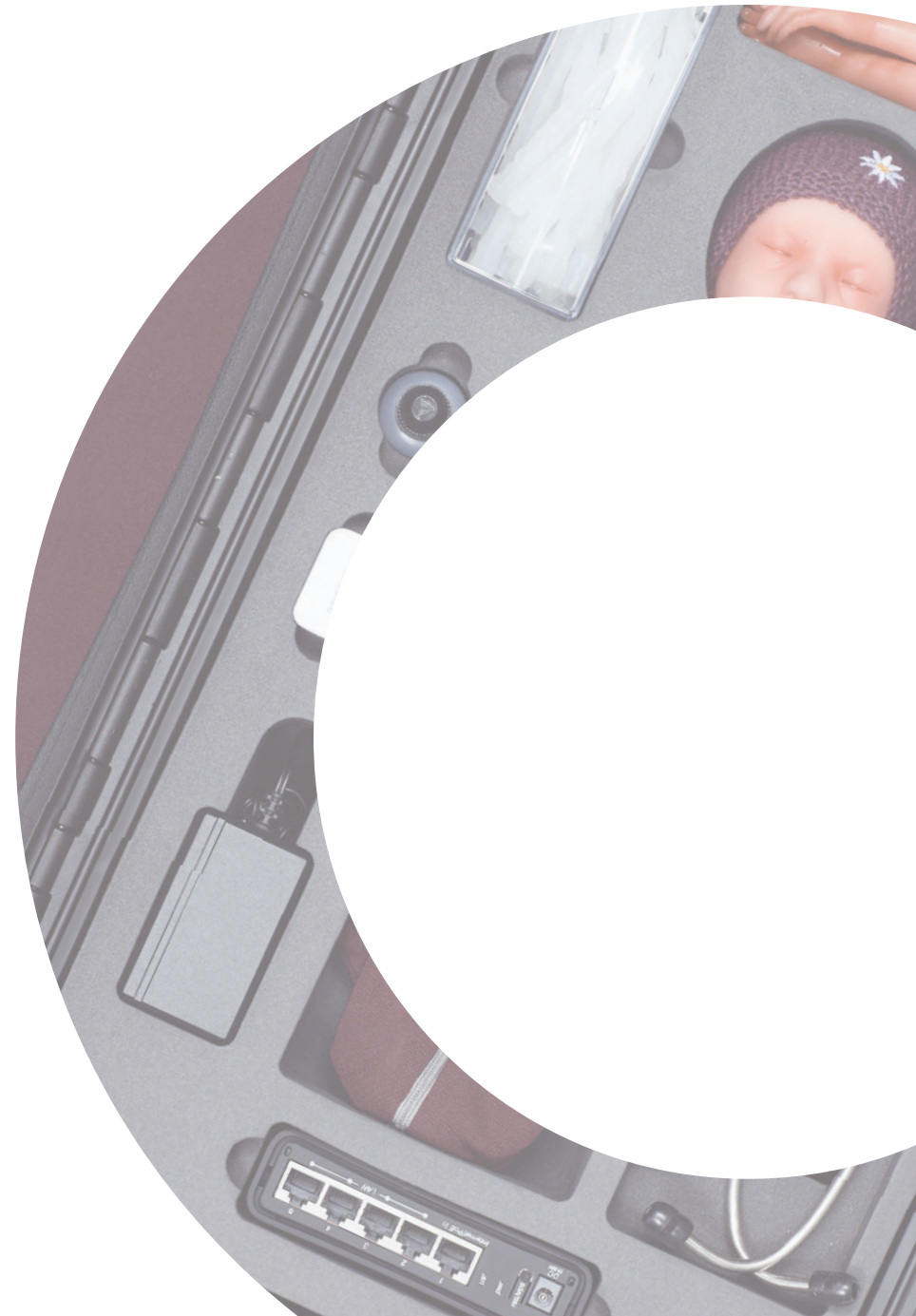

OPTIMIZED DETECTION OF ENDOTRACHEAL TUBES WITH TRANSPARENT TIPS



Paul features an automatic detection system for endotracheal tubes. Upon insertion, the tube is swiftly identified and showcased on the graphical user interface. Proper insertion situates the tube within the trachea, while incorrect placement results in its appearance either within the right main bronchus due to excessive depth or within the esophagus.

Tubes with colored tips, e.g. those from RÜSCH and Vygon, can be used without any problem due to their design and will be displayed correctly on the GUI.

In the case of some transparent tubes, the colored markings for the insertion depth on the end of the tube are too indistinct or inconsistent, which is why tubes of this kind are not always detected by Paul's sensors or cannot be consistently detected.

These include various tubes from Portex and, in particular, those from Mallinckrodt.

In order to be able to use tubes with transparent tips when training with Paul, you can use our tube painting kit to coat the interior of the tips of these tubes. This ensures that Paul's sensors are able to detect the different tubes.

Please make sure to avoid painting the outside of the tube since this can lead to paint deposits in Paul's airway and on the tubesensors.

Be advised, to use only the paint provided by SIMCharacters.

USING THE TUBE PAINTING KIT:

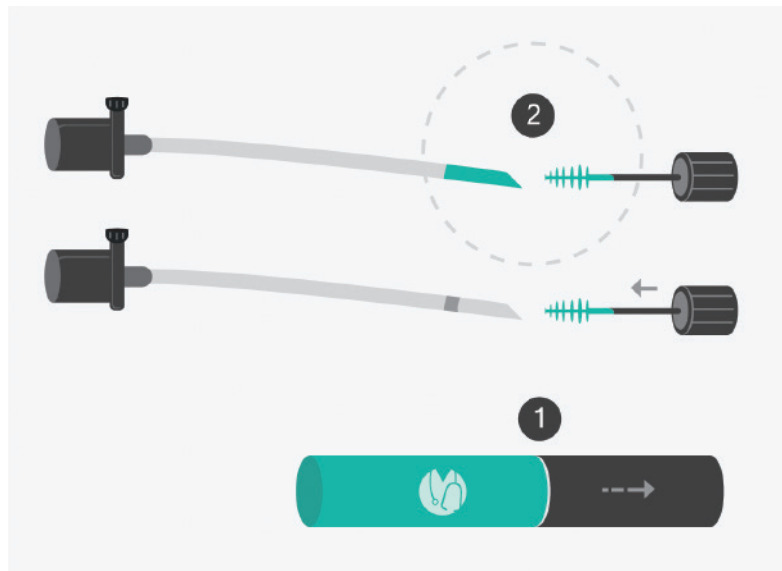

Please use a new, clean tube with an interior diameter (ID) not greater than #2.5.

1. Unscrew the small paintbrush out of the paint pot and remove any excess paint using the lip of the pot.

2. Insert the paintbrush inside the tube as far as is possible.

Slowly remove the paintbrush while twisting it.

The interior of the tube should be covered with a thin layer of paint to ensure proper ventilation.

Remove any excess paint from the exterior of the tube using a dry cloth.

Make sure to allow the paint to dry for 48 hours to ensure that there are no paint deposits in Paul's airway.



GENERAL SAFETY PRECAUTIONS:

As long as the paint is not dry, it can be washed off smooth surfaces with water.

The usual precautions when handling chemicals should be complied with. Make sure you avoid contact with eyes and mucus membranes and consult a doctor if these areas come in contact with the paint.

Please see the enclosed Safety Data Sheet for more safety precautions (according to Regulation (EC) No. 1907/2006 (REACH) and Regulation (EU) 2015/830)

SAFETY PRECAUTIONS



○ The administration of fluids through the body openings (mouth, nose, umbilical cord) of the simulator or through peripheral accesses must not be done under any circumstances, as it can cause severe damage to the simulator's electronics. Please do not use humidification systems for ventilation or incubator humidification. If fluids are accidentally administered into the simulator, please turn off the simulator immediately, do not turn it back on, and contact our support immediately!

- Before each training session, please intubate Paul several times with a tube lubricated with the care oil. **Please use only the silicone oil provided by SIMCharacters!** Not using the care oil can make intubation difficult and may damage the Paul's airways. Therefore, please apply a few drops of the provided care oil into both nostrils and into Paul's mouth before training and during longer training sessions.
- For nasal intubation, please use the Magill forceps supplied by us. This model (**KLM Martin**) does not have sharp edges at the joint area like other Magill forceps, which protects the corners of Paul's mouth from damage.
- Please use a maximum of a **size #2.5 (ID) tube** with a maximum outer diameter of 4.1 mm.
- Use only umbilical venous catheters with a maximum outer diameter of **4 Fr (French)**.
- The simulator must **not be defibrillated**.
- The simulator is splash-proof but not waterproof. Therefore, do not submerge the simulator in water.

MATERIAL	SIZE
Bag	250 ml
Mask	Preterm Air Rim Mask
Tube	# 2,5 mm ID (max. 4,1 mm OD)
Laryngoscope	(Foregger Size 0) or Miller Size 00
Magill forceps	KLM Martin (Artikel...
Umbilical venous catheter	3,5 French
Umbilical arterial catheter	3,5 French

TUBES	ID	OD
Rüsch Safetyclear	2,5	3,3
Rüsch Pedi Safety Silk	2,5	4
Vygon all types	2,5	4,1
Portex	2,5	3,4
Portex Type Cole	2,5	3,7
Mallinckrodt**	2,5	3,6

**The tubes from Mallinckrodt feature only a very subtle color marking at the distal end of the tube. This can lead to limited detectability of these tubes by the sensors in Paul.

- **Relieving a pneumothorax in Paul is not possible.** Punctures to relieve a pneumothorax should not be performed as they can cause severe damage to the simulator.
- Cutting the umbilical cord and placing peripheral accesses on the limbs (not in the area of the head and neck!) is possible. However, fluids must not be administered through these accesses either.
- Paul must **not be operated in an MRI** environment.
- Please do not install any additional programs on the trainer laptop or tablet as this can impair the performance of the entire system.
- If the simulator is not used for an extended period, please charge the battery at least once every 90 days to prevent damage.
- Store the simulator in a cool and dry place. Avoid operating temperatures higher than 30° Celsius, as the additional heat development can damage the electronics of the simulator. Therefore, please make sure to turn off heaters, incubators, etc., during training
- Please do not use disinfectants. These can cause damage (discoloration, cracking) to the silicone skin.
- **Please follow the instructions regarding appropriate configuration, troubleshooting technical issues, and using the preterm infant simulator. Also, pay attention to the additional warnings and notes in this manual. Damage caused by improper use is not covered by the warranty.**

ADMINISTRATION OF DRUGS AND FLUIDS DURING SIMULATION SCENARIOS



To protect the sensitive electronics and sensors from damage caused by moisture, it is not possible to administer liquids in Paul.

However, the administration of medications and fluids, and the preparation of these, is crucial during a training scenario to practice under realistic conditions.

WE THEREFORE RECOMMEND THE FOLLOWING FOR REALISTIC ADMINISTRATION OF DRUGS OR FLUIDS:

- Connect a three-way stopcock to an extension.
- Close the three-way stopcock towards the extension (toward the simulator) and connect a reservoir with sufficient filling volume (e.g., 500 ml) to the open part.
- Then, connect another three-way stopcock to the first three-way stopcock and subsequently seal the first stopcock, for example, with a bandage. This prevents the three-way stopcock from being opened towards the simulator.
- When training participants establish an access (peripheral or UVC), the prepared extension is connected to the access. The second three-way stopcock can be used by the participants as usual, allowing for the administration of drugs and fluids.
- The fluids will then not flow into the simulator but into the reservoir bag.

SYSTEM SETUP

Paul is part of a highly mobile simulation system: the patient simulator, control laptop, and vital monitor are ready to use in just a few steps, easy to transport, and therefore ideal for in-situ use. To work with Paul, a Wi-Fi connection through a dedicated network is necessary. The control laptop, Paul, and the patient monitor must be on the same network. This is automatically established via the provided Wi-Fi router.

WI-FI CONNECTION

- Please start by turning on the Wi-Fi router.
- First step, plug in the power cord; the router will then automatically start and create a standalone network.
- This process takes about 30 seconds to a minute.

The Wi-Fi network is pre-configured as „**Paul Network.**“



SIMCharacters Tip:

If large distances need to be covered between the control computer and Paul, various options are available to extend the network range. If we have not already provided the ideal solution for your needs during the system installation, our SIMCharacters technicians are ready to assist you in achieving the optimal configuration.

Please feel free to contact us at:

support@simcharacters.com





SIMULATOR CONTROL VIA TOUCHSCREEN

Both the control computer and the vital signs monitor can be operated via touchscreen. For mobile use of the simulation system, the monitor of the Laptop Studio can be folded down and the user interface can be operated via the touchscreen in tablet mode.

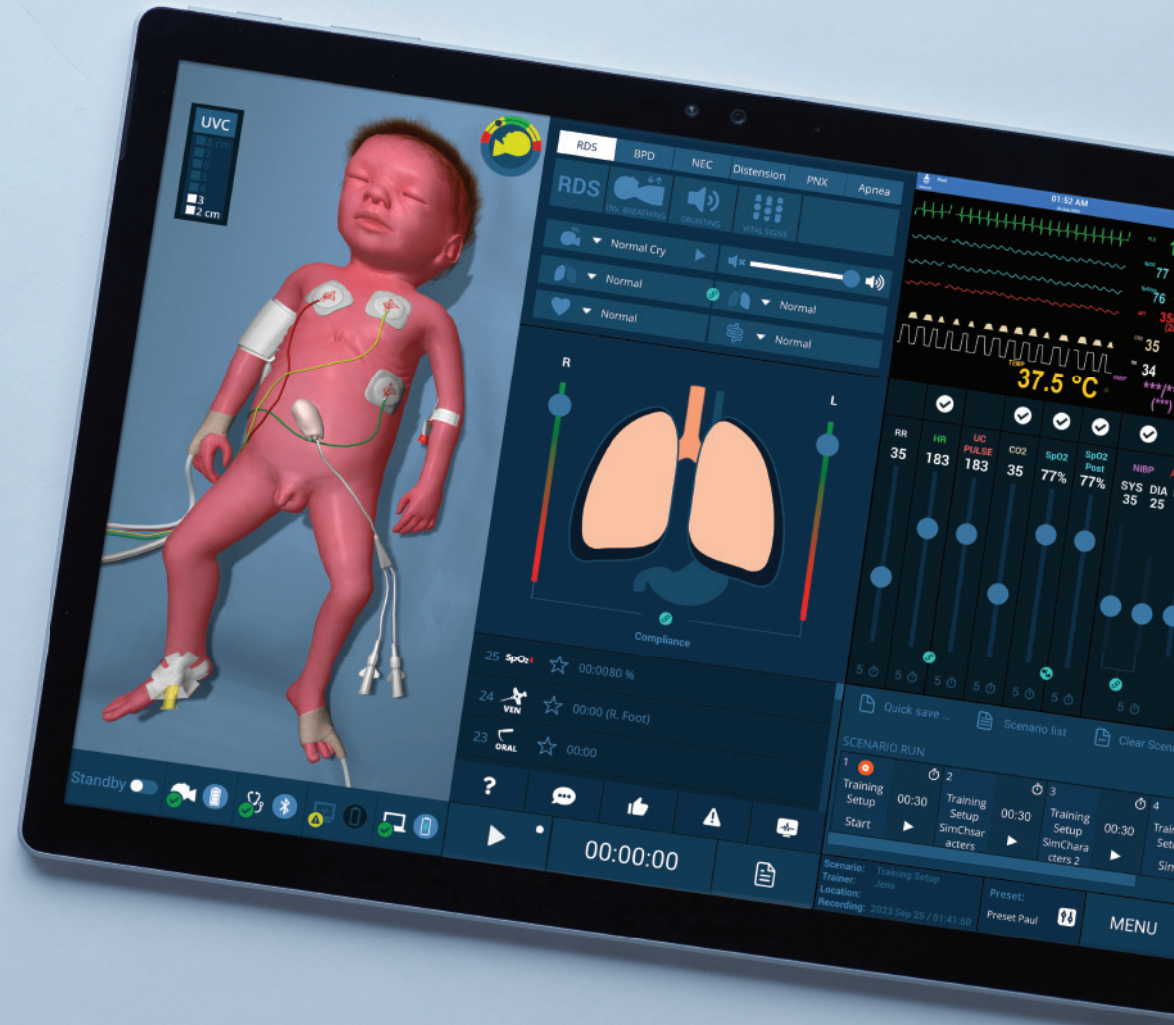

User interface
(GUI)
pre-installed!



SIMULATOR CONTROL LAPTOP

The control software (graphical user interface, GUI) is already installed on the laptop.

- To start the control software, please click on the **SIMCharacters icon** on the desktop of the laptop.

Paul and the patient monitor are controlled via the graphical user interface.

A detailed description of the controls can be found in the chapter „*The SIMCharacters User Interface*“, p. 23



PATIENT MONITOR

The software for the simulated patient monitor is also already installed on the tablet.

- To start the monitor software, please click on the **SIMCharacters icon** on the tablet's desktop.

The patient monitor is a touchscreen monitor. Training participants can use the monitor like a real patient monitor during training and, for example, set alarm limits, measure blood pressure, set automatic blood pressure measurement intervals and acknowledge alarms.

A detailed description of the controls can be found in the chapter „*The Patient Monitor*“, p. 52



PAUL

Paul does not have a power button. You can switch Paul on by either connecting him directly to the cable supplied or by placing him on the charging pad. While Paul is starting up, you should not move him for a short time, as all motors and sensors are calibrated during this phase. You should also not change the lighting conditions during this phase, as several sensors in Paul react to light.

HOW YOU RECOGNISE THAT PAUL IS READY FOR USE:

- As Paul switches on, a **blue light flashes** under Paul's skin on the left side of his stomach.
- As soon as he is connected to the control software, the light stops flashing and **Paul starts breathing**.
- A **green tick** appears above the Paul icon in the system status bar on the user interface.

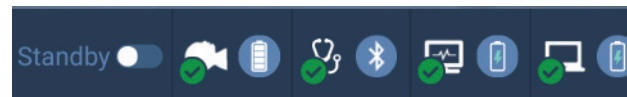

You can also see Paul's charge status on the user interface. If you move the cursor over the battery symbol next to Paul, his battery status appears as a percentage. When Paul is charging, you will see a charging flash above the battery symbol.

SIMCharacters Tip:

Paul charges fastest when he is connected with the cable and is in standby mode.

If Paul is in standby mode but connected to the control software, the **light** under his belly skin **flashes green**. This indicates that he will be ready for use again immediately after „waking up“.

After each scenario, you should reconnect Paul to the charging cable again during the debriefing time or place him on the charging pad to ensure battery operation for the entire training session. To remind you of this, the message **„Please connect Paul to the charging cable or place him on the charging pad!“** appears on the user interface at the end of each scenario.

Paul also does not have its own switch-off button. He is switched off via the software (**Menu > Turn off**). If the software has been closed and Paul has been shut down, the **light under Paul's skin flashes yellow** as long as he is still connected to the charging cable or on the charging pad. **To switch Paul off completely, please disconnect him from the cable or remove him from the charging pad.** The light will then switch off completely.



SIMCharacters Tip:

If you want to charge Paul the day before a training session, for example, or just want to check his battery level without starting up the whole system, simply connect him to the charging cable.

He will then switch on and the blue light under his skin will start flashing. If you now turn him on his stomach, you will see his battery indicator under his skin on his back.

When Paul is sufficiently charged, disconnect him from the cable again and switch him off with the magnet provided by moving the magnet back and forth over Paul's large fontanel several times. Please make sure that the light under Paul's abdominal skin no longer lights up.

The battery indicator also appears when Paul is connected to the control software and you



USING THE SIMULATION STETHOSCOPE

Paul's heart, lung and bowel sounds can be auscultated using the simulation stethoscope supplied. To prevent technical background noise during auscultation of Paul, the sounds are generated by the physiology server depending on the auscultation location and automatically transmitted to the stethoscope through a Bluetooth connection. Depending on the position of the stethoscope, the different sounds (heart, lungs, bowel) are mixed according to intensity and output.

To switch on the stethoscope, briefly press the switch-on button on the front of the stethoscope. The **status indicator first flashes blue** while the connection is being established and then **flashes green** when the connection to the simulator is established. On the user interface, the **green tick** above the stethoscope icon indicates that the stethoscope is connected. If the stethoscope status indicator **flashes yellow** or does not flash at all, the stethoscope battery (AA) must be replaced.



LOGIN TO THE CONTROL LAPTOP

LOGIN

- Once you have started the control software, the login window appears.
- If you are already registered as a user, you can log in with your name and personal password in the login window.
- If you do not have a user account yet, you can create one under „**Register**“ on the top right-hand corner of the window.

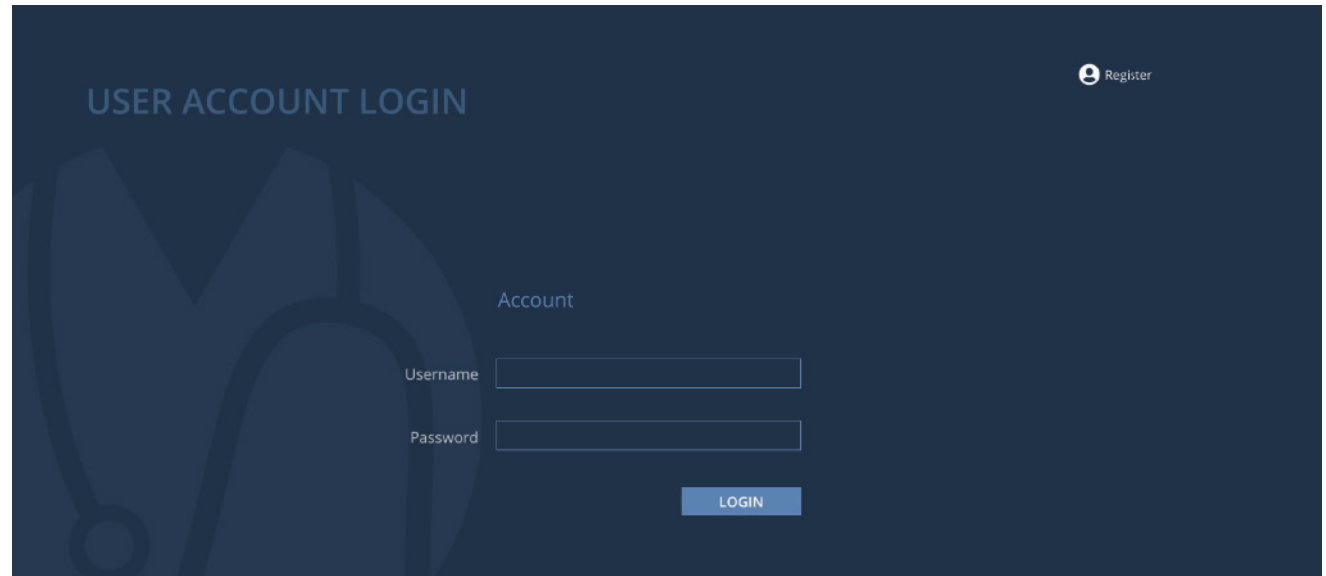

The screenshot shows the 'USER ACCOUNT LOGIN' window. In the top right corner, there is a 'Register' link with a user icon. The main area is titled 'Account' and contains two input fields: 'Username' and 'Password'. Below these fields is a blue 'LOGIN' button. The background features a faint, stylized illustration of a character's head.

REGISTER

- To register a new user, please enter first and last name, as well as a user name and a password.
- Then click on „**Register**“ and you will be taken back to the login window.

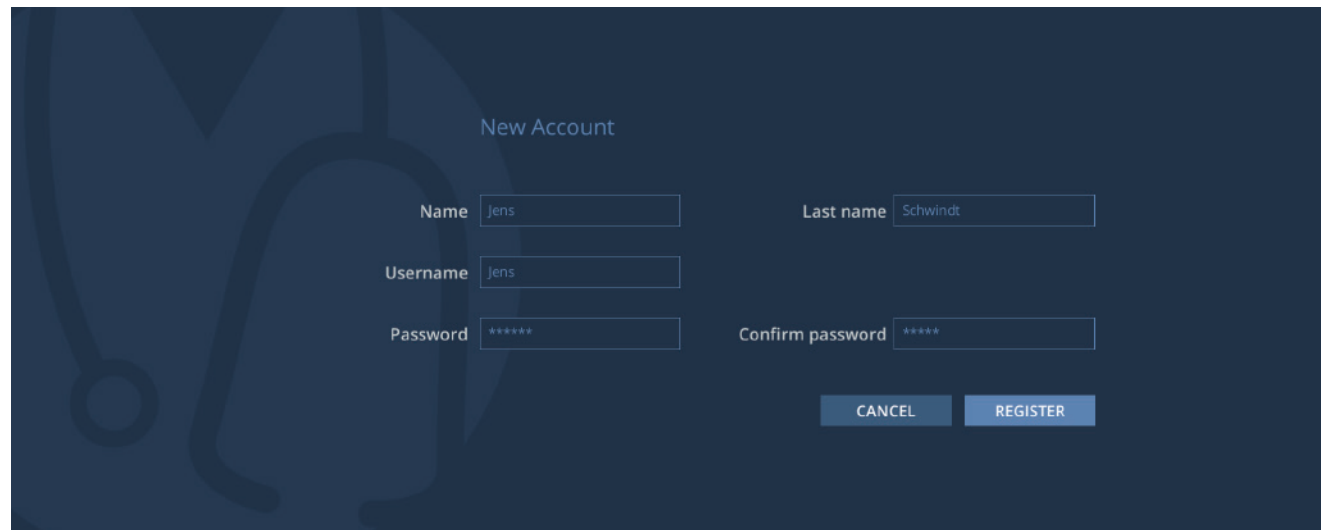

The screenshot shows the 'New Account' registration window. It contains four input fields: 'Name' (with the value 'Jens'), 'Last name' (with the value 'Schwindt'), 'Username' (with the value 'Jens'), and 'Password' (with masked characters '*****'). There is also a 'Confirm password' field with masked characters '*****'. At the bottom right, there are two buttons: 'CANCEL' and 'REGISTER'. The background features a faint, stylized illustration of a character's head.

PROJEKT DETAILS

You are now logged into the system as a user and can add other registered users to your training or enter a training location on the **project details page**. You can now save basic settings and scenarios and use your own scenarios and scenarios that other users want to share with you for your training.

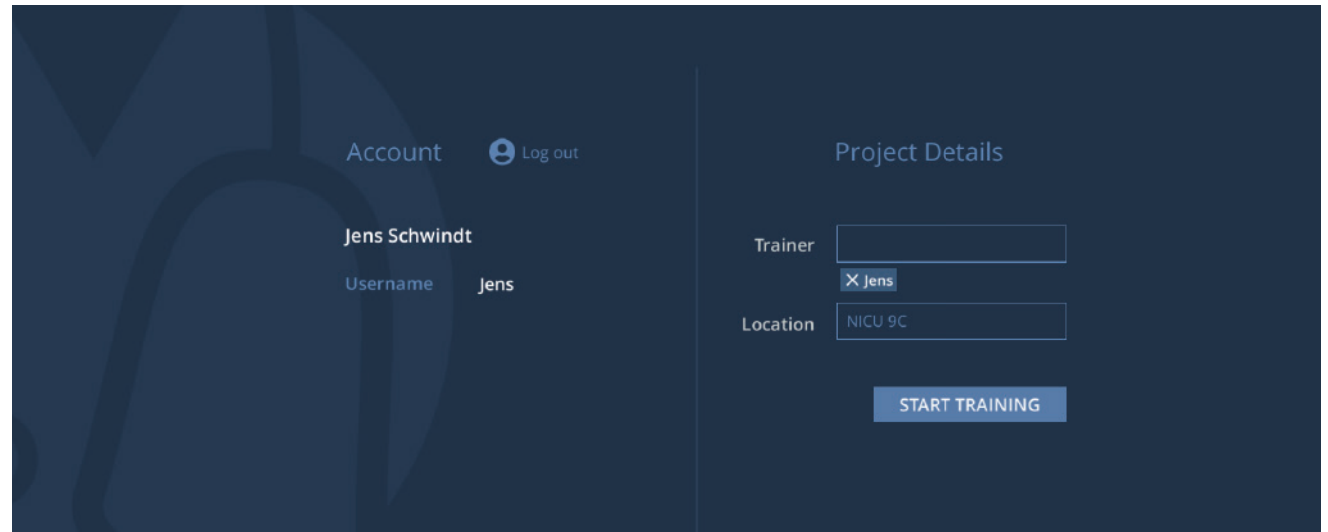

The screenshot shows a dark blue user interface. On the left, under the heading "Account", the user's name "Jens Schwindt" is displayed, with "Username" and "Jens" below it. A "Log out" button with a user icon is in the top right of this section. On the right, under the heading "Project Details", there are two input fields: "Trainer" with a dropdown menu showing "Jens" and an "X" to clear it, and "Location" with the text "NICU 9C". A blue "START TRAINING" button is positioned below these fields.

START TRAINING

The registration process is completed by clicking on **„Start training“**.

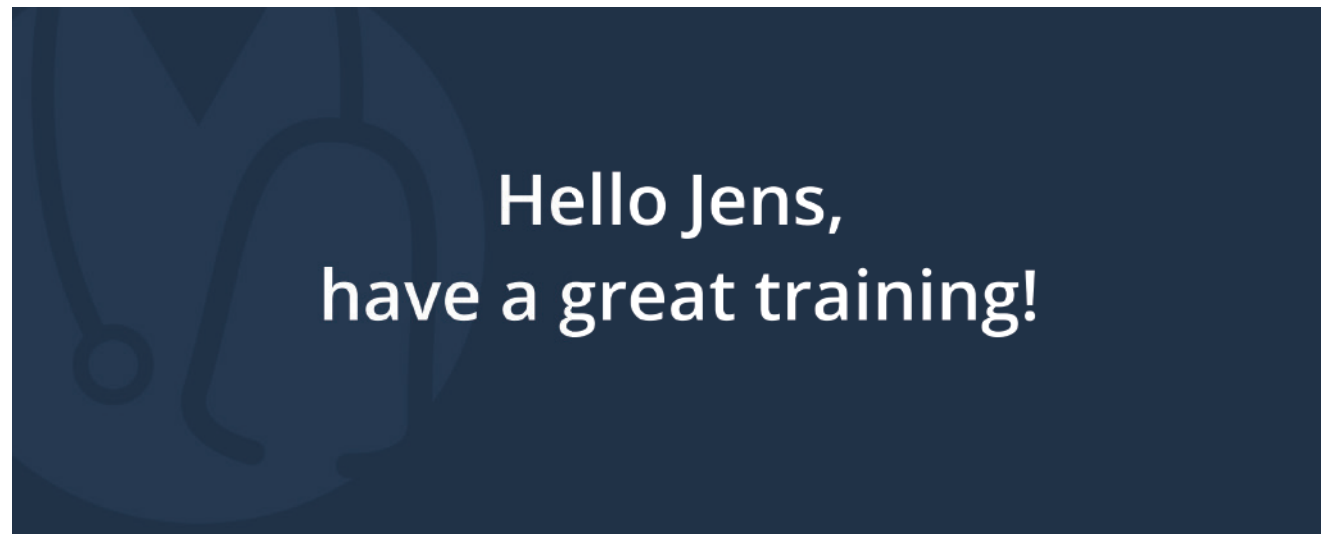

BEFORE YOU START

In the „**Please treat Paul with care**“ window, new users will once again find the most important instructions for safe and smooth operation of the simulation system when they first start using it.

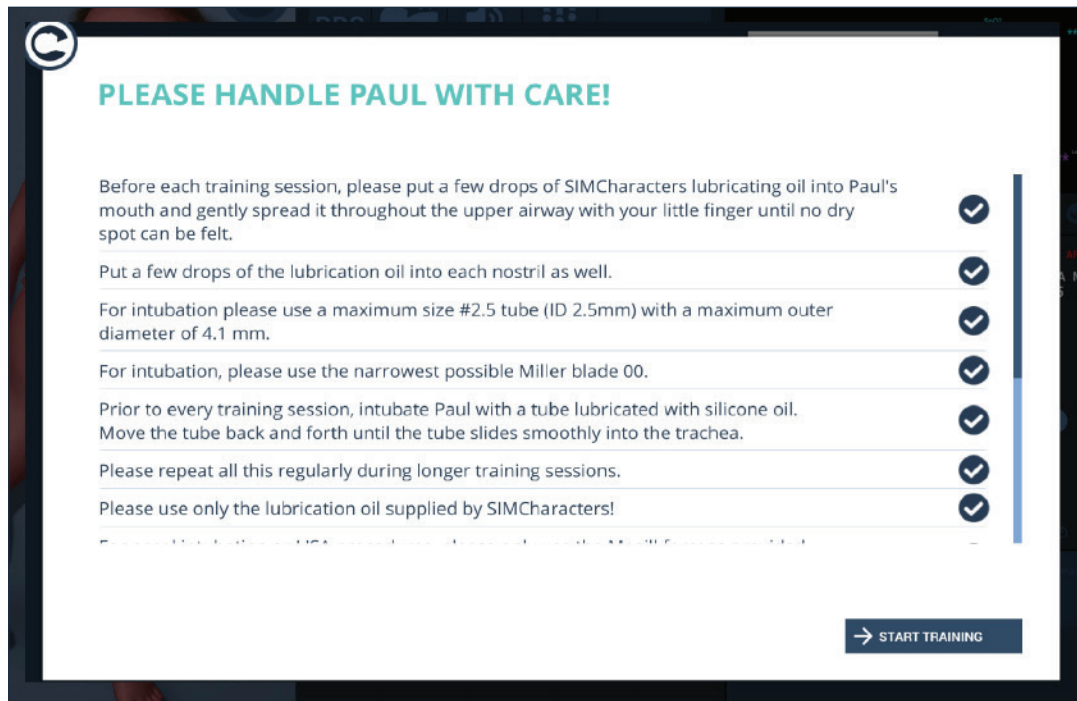

Please be sure to pass this information on to your training participants (and your team of trainers if applicable) at every training session! Failure to observe these safety instructions may result in serious damage to the simulator and invalidate the warranty!



- Before each training session, please drip several drops of the silicone oil supplied into Paul's mouth. Carefully smear the oil over the entire upper airway with your little finger so that you can no longer feel any dry patches.
- Also drip a few drops of the silicone oil into each nostril.
- For intubation, use a maximum tube size #2.5 (ID 2.5 mm) with a maximum outer diameter of 4.1 mm.
- Please use the narrowest possible Miller blade size 00 for intubation.
- Please intubate Paul before each training session using a tube lubricated with silicone oil. Move the tube back and forth in the trachea until it can be moved easily throughout the trachea.
- Please repeat these steps regularly during longer training sessions.
- Please use only the silicone oil supplied by SIMCharacters!
- Please use only the Magill forceps supplied for nasal intubations (and for LISA techniques).
- Please only ventilate Paul with room air (21%) and never use humidification.
- Please do not administer surfactant or other fluids into the airway.
- Please do not insert any peripheral accesses in the area of the head or neck.
- **Do not under any circumstances administer fluids into the umbilical cord!**
- Please do not administer any type of fluid into the extremities.
- Please do not puncture the thorax.

The tablet interface displays the following information:

- Top Bar:** RDS, BPD, NEC, Distension, PNX, Apnea. Time: 01:52 AM.
- Vital Signs:**
 - HR: 184
 - RR: 77
 - SpO2: 76
 - Temp: 37.5 °C
 - CO2: 35
 - MAP: 35/25 (28)
 - SpO2 Post: 77%
 - NIBP: 35/25/28
 - ART: 34
- 3D Model:** A newborn baby with various sensors attached to its chest and limbs. A UVC camera view is shown in the top left corner.
- Lung Diagram:** A central diagram of lungs with 'Compliance' sliders for the Right (R) and Left (L) sides.
- Scenario Run Table:**

Scenario	RR	HR	UC PULSE	CO2	SpO2	SpO2 Post	NIBP	ART	TEMP
1	35	183	183	35	77%	77%	SYS 35 DIA 25 MAD 28		37.5°
- Bottom Bar:** Standby, communication icons, a play button, and a timer showing 00:00:00.

THE SIMCHARACTERS USER INTERFACE (GUI)

Click on the „**Start training**“ button to open the SIM-Characters user interface.

All of Paul’s functions and the patient monitor are controlled via the GUI (Graphical User Interface).

THE GUI IS DIVIDED INTO THREE COLUMNS:

1. 3D model of Paul that depicts all functional states of the simulator in real time.
2. retrieval of pre-programmed symptom complexes, control of lung function, playback of patient sounds and playback of sounds into the simulation stethoscope. Control of the debriefing system.
3. control of the vital signs monitor, starting and saving scenarios, settings.

- 1
- 2
- 3



The interface is divided into three main sections:

- Left Panel (Character View):** Shows a baby character with various medical sensors attached. A 'UVC' (Ultrasound) menu is visible on the left, with options for 8 cm, 7, 6, 5, 4, 3, and 2 cm. A 'Standby' toggle is at the bottom left.
- Center Panel (Control & Compliance):** Features a top menu with conditions: RDS, BPD, NEC, Distension, PNX, and Apnea. Below are icons for 'RDS', 'INV. BREATHING', 'GRUNTING', and 'VITAL SIGNS'. A 'Normal Cry' audio control is present. A central diagram of lungs has a 'Compliance' slider at the bottom. A list of events is shown below the diagram:
 - 25 SpO₂ 00:0080 %
 - 24 VEN 00:00 (R. Foot)
 - 23 ORAL 00:00
- Right Panel (Monitoring Dashboard):** Displays vital signs and waveforms. At the top, it shows 'Paul' and '01:52 AM'. Waveforms include PLS (Pulse), SpO₂ (77% and 183), SpO₂ (76% and 194), ART (35/25 (28)), CO₂ (35), RR (34), and TEMP (37.5 °C). A 'NIBP' status is shown as '*** ***)'. A table of vital signs is located below the waveforms:

RR	HR	UC PULSE	CO ₂	SpO ₂	SpO ₂ Post	NIBP	ART	TEMP
35	183	183	35	77%	77%	SYS 35, DIA 25, MAD 28		37.5°

 At the bottom right, there is a 'SCENARIO RUN' section with four buttons: '1 Training Setup 00:30 Start', '2 Training Setup 00:30 SimChsars', '3 Training Setup 00:30 SimCharacters 2', and '4 Training Setup 00:30 Sim'. A 'MENU' button is at the bottom right corner.

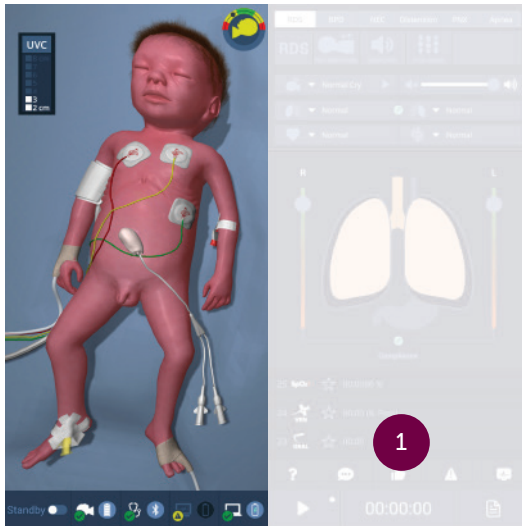

CONTROL AREA FOR PAUL IN THE 3D SIMULATION

In this area, Paul is displayed in a real-time 3D simulation. For example, you can see Paul's breathing movements at the set breathing rate. Paul's sensor system also recognises measures that your training participants perform on Paul. For example, mask ventilation, intubation or the insertion and advancement of an umbilical venous catheter are displayed in the animation. Measures that cannot be recognised by the sensors, e.g. attaching an ECG or inserting a peripheral access, can be set by the trainer team using the input bubbles and then also appear in Paul's graphic animation.



SIMCharacters Tip:

The aim of this type of control is to harmonise the visual impression that your training participants have of Paul in the scenario with the trainer's view of Paul on the user interface. This should make the subsequent debriefing easier.

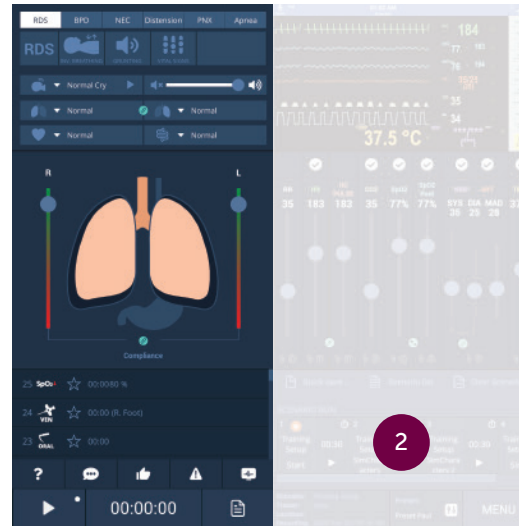

CONTROL AREA FOR SYMPTOM COMPLEXES, LUNG FUNCTION, SOUNDS AND DEBRIEFING

In the center area of the user interface, you have the option of

- selecting the predefined symptom complexes RDS, BPD, NEC, distension, pneumothorax and apnoea.
- changing the compliance of the lungs.
- to simulate a pneumothorax.
- setting the sounds for the heart, lungs and bowel that are emitted via the stethoscope.
- selecting the patient sounds.
- starting a training scenario and making time-stamped entries in the debriefing system.



PATIENT MONITOR CONTROL AREA AND SETTINGS

On this part of the display is shown:

- the simulated patient monitor as seen by the training participants in the training room is displayed.
- where the simulated patient monitor is controlled.
- where you can access the settings menu, save scenario configurations and load saved scenarios.

CONTROL PAUL THROUGH THE 3D SIMULATION

If you move the mouse pointer into the area of Paul's 3D simulation, input bubbles will open.

Here you can transfer actions that are set by the training participants but are not detected by Paul's sensors to the 3D simulation.

If you click on the corresponding bubble, the following options open for selection:

1. Repositioning of the nasal/oral tube and endotracheal administration of medication



2. ECG / Capillary Refill Time



3. Switching pulses on and off

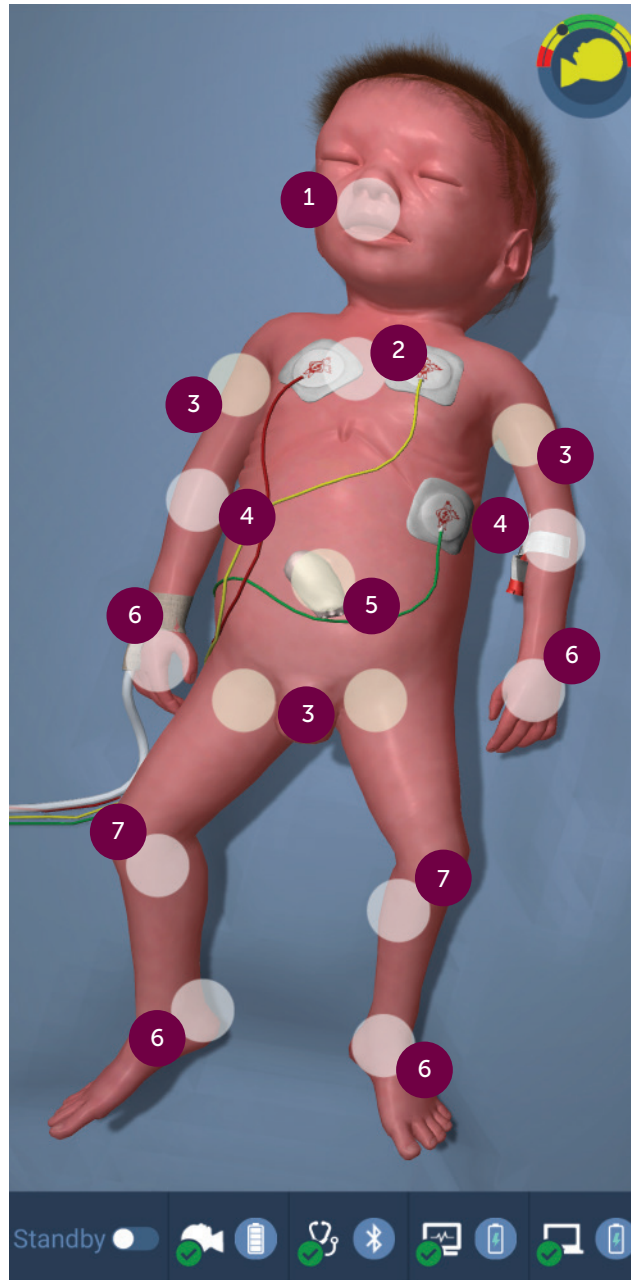

4. Blood pressure cuff / peripheral vascular access / medication / arterial line



5. Umbilical venous catheter/ umbilical arterial catheter/ medication / switching pulses on and off



6. Pulse Oximetry Sensor / peripheral vascular access / medication / arterial line



7. Blood pressure cuff





PAUL'S FEATURES IN DETAIL

BREATHING

Paul has highly realistic upper airways and a physiological lung. This enables the simulation of respiratory pathologies specific to premature babies and the training of all necessary measures under highly realistic conditions.

NORMAL SPONTANEOUS BREATHING

Once Paul has been switched on and the SIMCharacters control software has booted, Paul breathes regularly with a physiological respiratory rate of around 45 breaths per minute and normal lung compliance typical in a preterm of his size.

The respiratory rate can be reduced and increased using the "AF" controller in the monitor area directly to the right of the animated lungs.

The minimum breathing rate is 0/min (apnoea), the maximum is 100/min.

The small clock below the slider bar for the respiratory rate makes it possible to automatically change the respiratory rate over any defined period of time. The default setting is 5 seconds.

The manikin always breathes at the respiratory rate currently defined and the same respiratory rate is displayed in the 3D animation and the animated lung. When respiration is normal, the chest of the manikin rises and falls and the abdomen also moves slightly, synchronised with every breath.

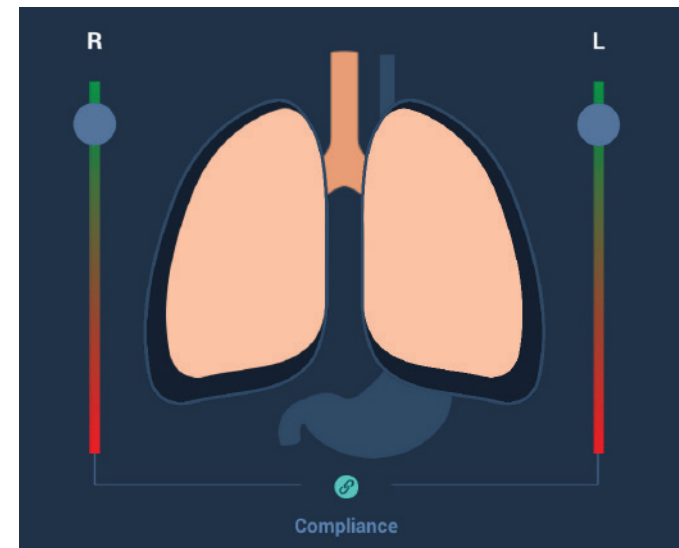
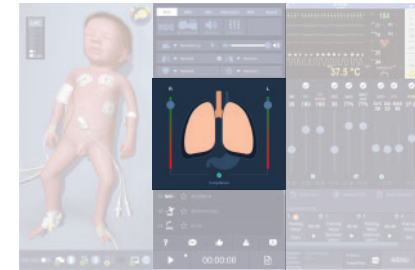

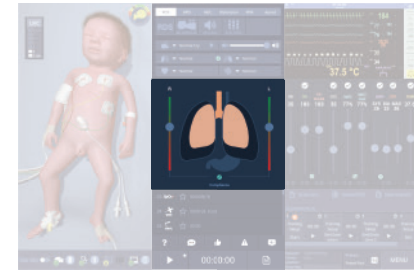

CHANGING LUNG COMPLIANCE

Paul has a physiological lung which makes it possible to make changes in terms of lung compliance during a training session.

The compliance is defined by means of the slider bar directly next to the lung on the GUI.

For general compliance changes, we recommend that both lungs are connected (using the **"Connect"** button) so that the compliance of both lungs changes to the same extent at the same time.

When the compliance is reduced, the lung volume is also reduced, as a result of which the animated lung becomes smaller and indicates reduced compliance.

The manikin is now more difficult to ventilate.

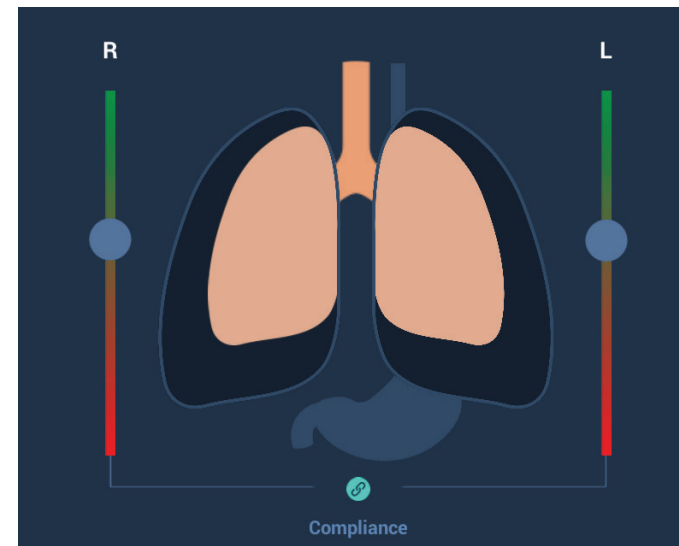

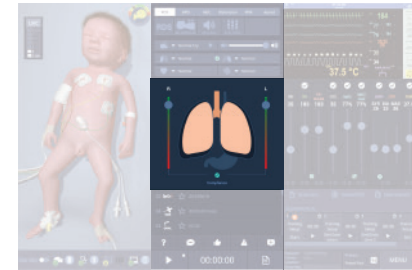

PNEUMOTHORAX

The worst-case scenario of reduced compliance with Paul is a pneumothorax.

As a pneumothorax will usually occur unilaterally, it is recommended to cut the link between the two lungs using the „**Connect**“ button to simulate a pneumothorax.

A pneumothorax of the right or left lung can now be left lung can be set.

In the case of a unilateral pneumothorax, the ventilated side of the chest now predominantly rises on the simulator. On the side of the pneumothorax, only very slight chest elevations or no more chest elevations are recognisable. On the side of the pneumothorax, only weakened or no breath sounds can now be auscultated.

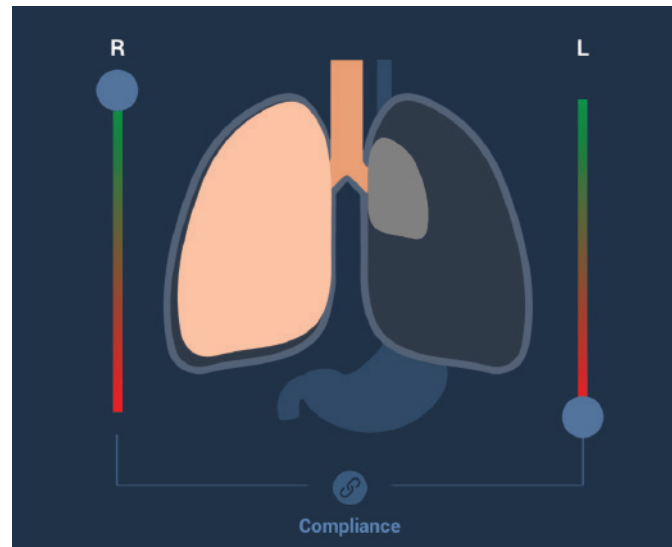

ATTENTION:

The thorax must not be punctured in order to relieve the pneumothorax!

This can cause major damage to the technology installed in the chest.

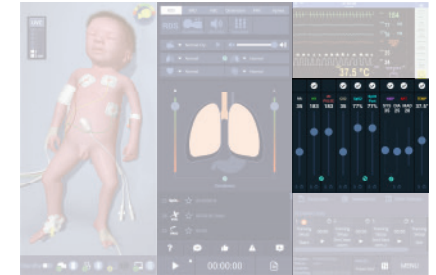

CYANOSIS AND HYPEROXIA

The simulator has several LED lights in the head.

These can simulate cyanosis and hyperoxia.

At a normal oxygen saturation between 97 % and 99 %, the LEDs are in standby mode.

The peripheral saturation (SpO_2) can be changed by dragging the slider.

At a peripheral saturation < 88 %, a blue discolouration appears in the area of the head, which increases in intensity as the saturation continues to decrease.

At a peripheral saturation > 99 %, a red colouration increases in intensity in these areas.

This discolouration can be seen both on the simulator and in the 3D animation of Paul on the GUI.

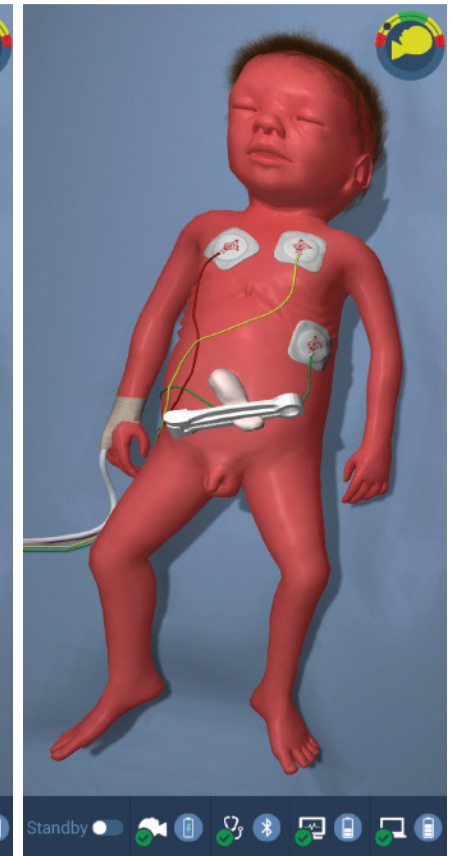
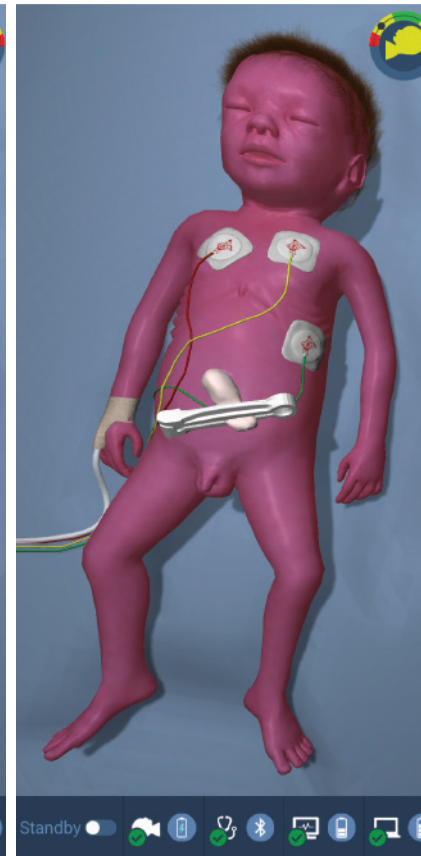
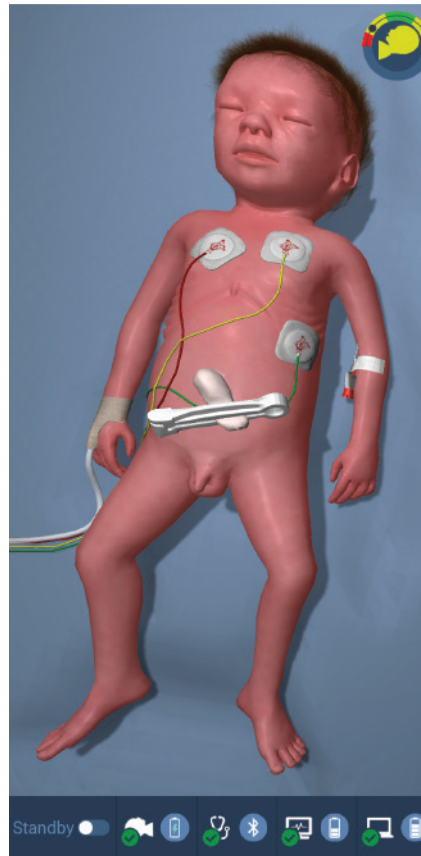

PAUL'S FEATURES IN DETAIL

VENTILATION

HEAD POSITIONING

Thanks to his physiological lungs, Paul can be ventilated manually and mechanically under realistic conditions. Efficient manual ventilation can only be performed if the head is in the neutral position (sniffing position).

The correct head position is displayed on the user interface in real time.

If the head is not in the neutral position, the chest does not rise or does not rise sufficiently during ventilation.

If the head is overextended, the abdomen will rise during ventilation; if the head is too bent, neither the chest nor the abdomen will rise. The green, yellow and red area can be changed in the pre-sets (see chapter „Pre-sets“, p.46).

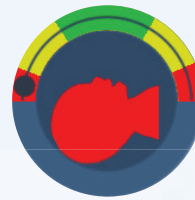

hyperextended

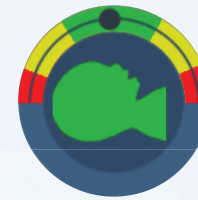

neutral

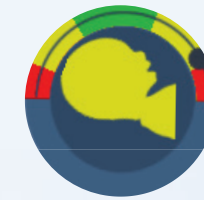

bent



MANUAL VENTILATION

If Paul is being ventilated manually, e.g. with a Perivent® system or bag, this is recognised by the simulator and displayed on the GUI.

The ventilations are displayed at the current ventilatory rate in the 3D simulation of Paul, the animated lung and, if an ECG is attached, also on the RR curve of the vital signs monitor.

Ventilation can already take place if there is still spontaneous breathing but it is no longer sufficient. PEEP can also be administered via a ventilation mask.

The effectiveness of the ventilation can be seen in a separate window that appears under ventilation.

Peak pressure (PIP), PEEP and tidal volume (VT) are displayed here. This window can be shown or hidden as required.

The optimum (green) range for the tidal volume can be customised in the simulator presets (see chapter „Pre-sets“, p.46).

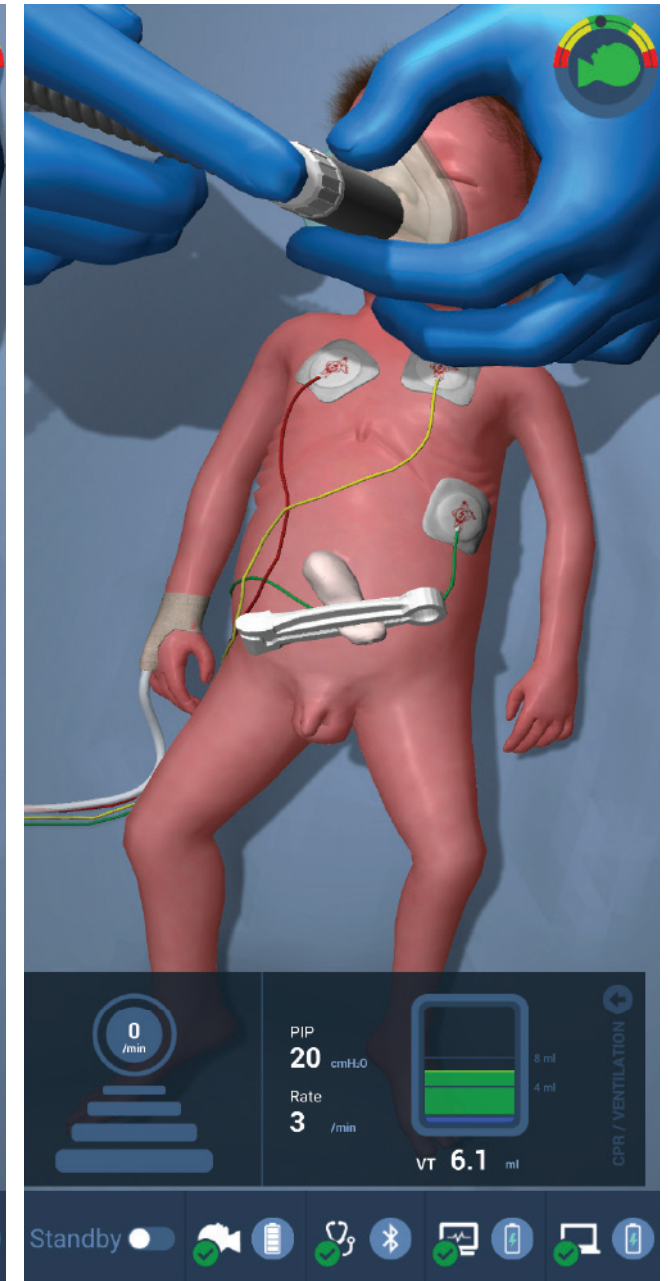
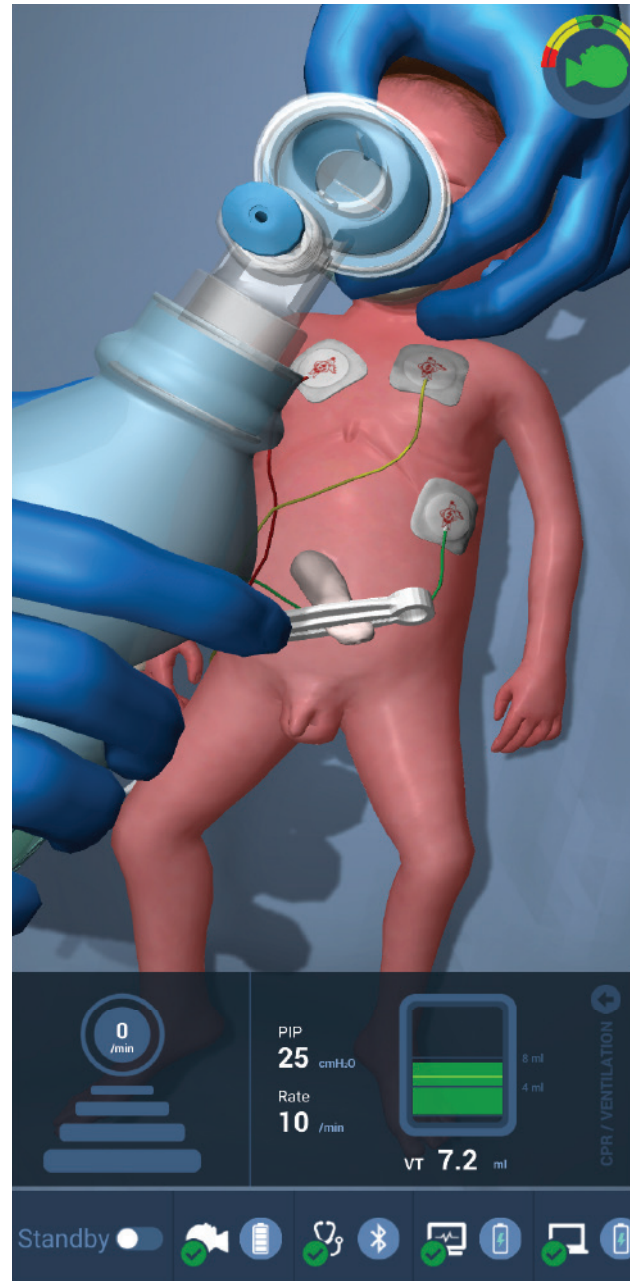

INTUBATION

Paul can be intubated with an uncuffed tube (**max. size #2.5 ID**).

During intubation, the tube appears on the 3D animation of Paul and in the trachea of the animated lung. The tube depth is detected by the sensors and displayed on the GUI.

If the tube is advanced beyond the bifurcation of the trachea, it is finally positioned in the right main bronchus. The left lung collapses in the 3D animation and turns grey. If ventilation is now performed, only the chest on the right side rises, the left side of the chest no longer moves.

If the tube is pulled back in front of the bifurcation, both sides of the chest rise again under ventilation.

Paul can be intubated **nasally or orally**. However, this is not recognisable for the sensor system. For the European region, the display on the GUI is set by default for nasal intubation, for the Anglo-American region for oral intubation. If required, this can be changed via the bubble in the area of the mouth and nose in the 3D simulation of Paul and in the system settings.

If Paul is **intubated incorrectly into the oesophagus**, the oesophagus and stomach in the lung animation area turn red and only Paul's stomach rises under ventilation.

Both correct and incorrect intubations are displayed in the integrated debriefing system.



SIMCharacters tip:

Plaster strips for tube fixation, such as Steri-Strips®, do not adhere well to silicone simulators like Paul. We therefore recommend that you first apply a strip of silicone plaster (**e.g. Mepitac®**) to the areas of skin where the Steri-Strips® will ultimately be attached.

The plaster strip can then be firmly attached to it.

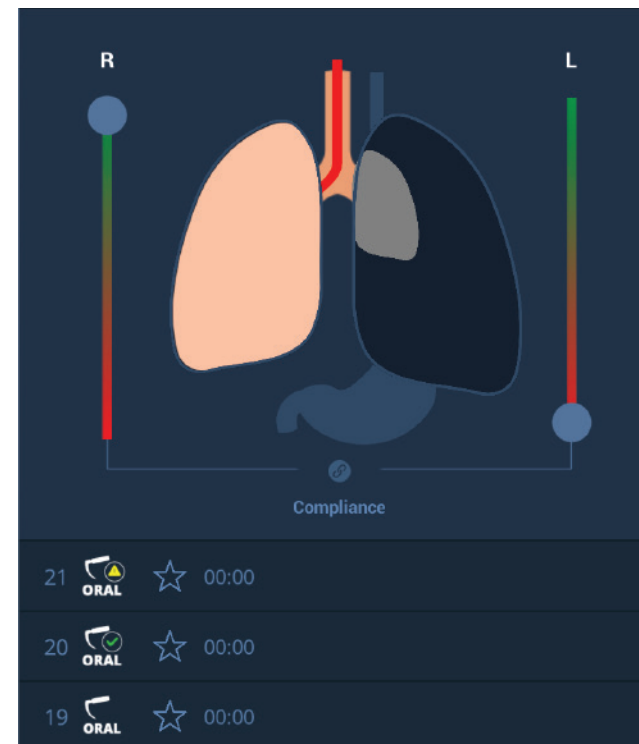
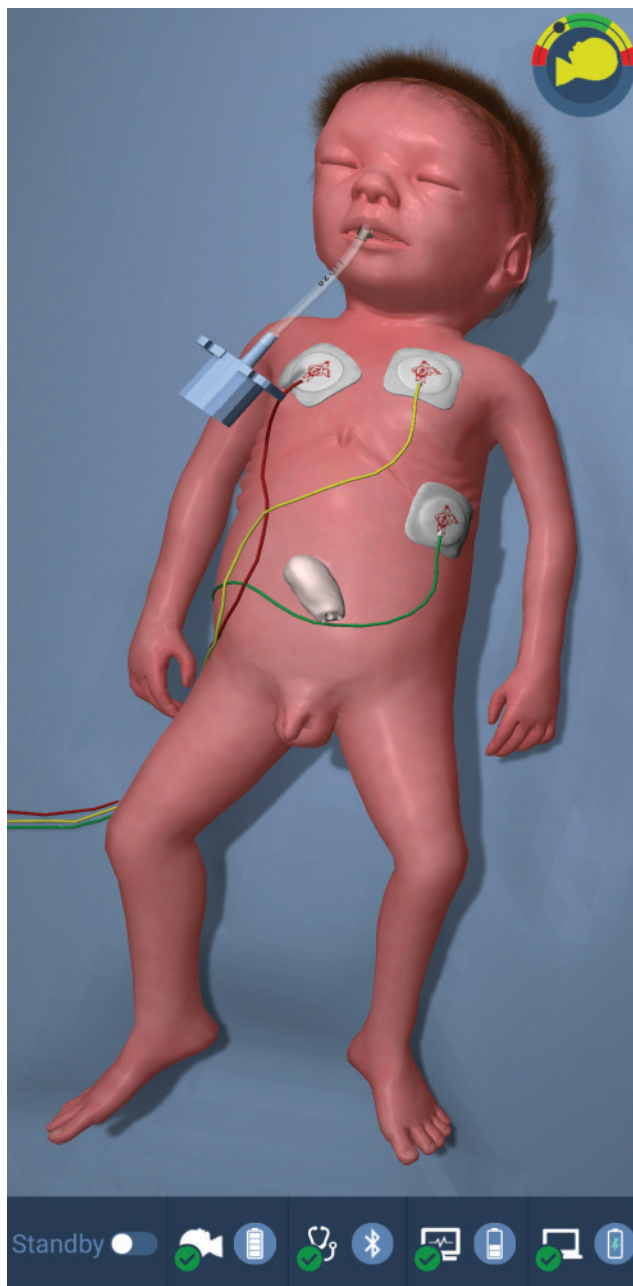

CAUTION:

Intubate Paul several times with a tube lubricated with SIMCharacters silicone oil before each training session (and repeatedly for longer training sessions).

Only use the silicone oil supplied by SIMCharacters!

Never administer drugs, fluids or surfactant into Paul's lungs, as this can cause serious da-



PAUL'S FEATURES IN DETAIL

CIRCULATION

PALPABLE PULSES

Pulses can be palpated on all four of Paul's extremities, both brachial pulses and both femoral pulses. The pulses can be switched on and off individually using the bubbles in the upper arm and femoral area. A yellow bubble indicates an active pulse, a red bubble indicates a switched-off pulse. The intensity of the pulse can also be changed in the pre-sets (see chapter „Pre-sets“, p.46).

In postnatal scenarios with an umbilical cord, an **umbilical cord pulse** can also be felt (at 12.00 o'clock above the umbilical cord under the skin). If Paul is postnatally in a state of massive circulatory insufficiency (heart rate < 60/min), the umbilical cord pulse can be decoupled from the heart rate and a lower pulse (or a non-palpable pulse) can be set on the umbilical cord than indicated by the heart rate in the sense of a **pulse deficit**.

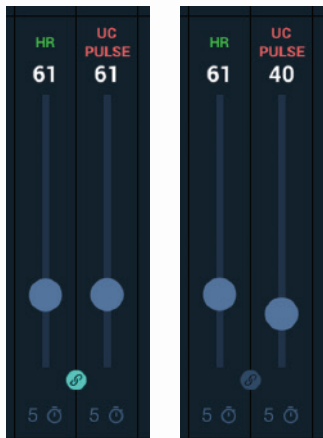

A. BRACHIALIS PULSE



CHEST COMPRESSIONS

Chest compressions can be performed on Paul with a realistic impression depth (approx. 1/3 of the thorax diameter).

1. During chest compressions, hands appear on the 3D animation to indicate that chest compressions are being performed.
2. If chest compressions are performed, a pop-up window opens automatically to show the effectiveness of the chest compressions and ventilations.

The display window can be shown or hidden as required.

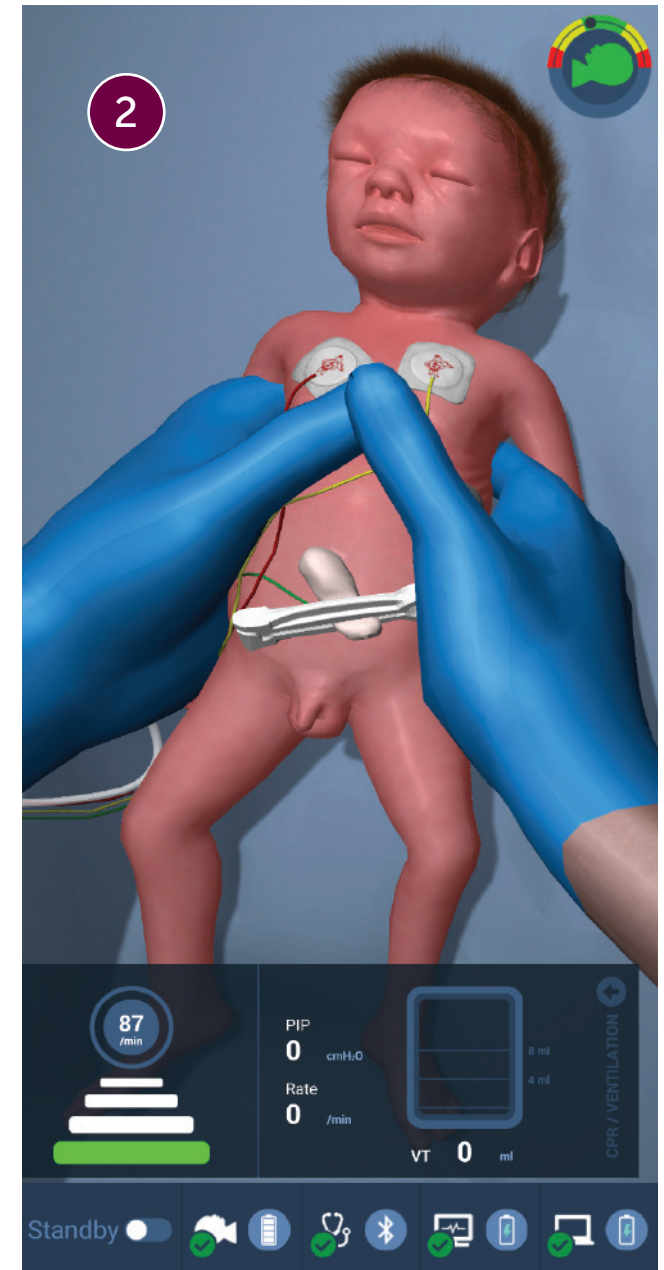
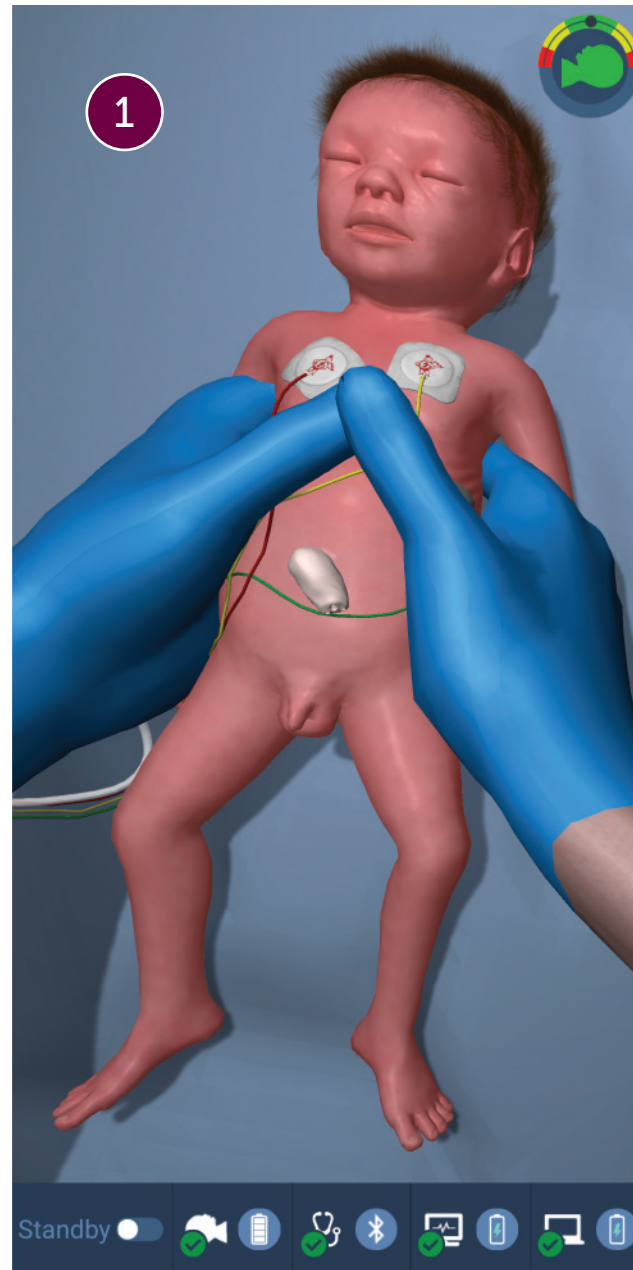

PERIPHERAL ACCESSES

Peripheral accesses (24GA or 26GA) can be inserted into all of Paul's extremities. Paul's silicone skin will always close again after the access is removed. If necessary, all four extremities can be easily replaced.

Please note that peripheral accesses must never be placed in Paul's head or neck area. This can lead to serious damage to the technology incorporated in these areas.



SIMCharacters Tip:

Please point out to your training participants that they will have to puncture a little deeper under Paul's skin than usual when inserting a peripheral access, as the plastic cannula of the indwelling venous cannula is rather difficult to push under the silicone skin.



Please note that no drugs or fluids may be injected into the peripheral accesses in Paul!

We recommend using a bag system with a three-way stopcock for the realistic injection of drugs and fluids.

(see „Administration of medication and fluids in simulation scenarios“, p. 11)



SIMCharacters Tipp:

Plaster strips for vascular access fixation, such as Steri-Strips®, do not adhere well to silicone simulators like Paul. We therefore recommend that you first apply a strip of silicone plaster (e.g. Mepitac®) to the areas of skin where the Steri-Strips® will ultimately be attached. The plaster strip can then be firmly attached to it.

PLACEMENT OF AN UMBILICAL VENOUS CATHETER

1. Paul has a realistic umbilical cord, that can be cut physically with a scalpel or scissors.
2. The cutting of the umbilical cord is detected by sensors in the umbilical cord and indicated on the user interface by the disappearance of the umbilical clamp. (In the integrated debriefing system, the umbilical cord cutting icon also appears).
3. If an umbilical venous catheter (UVC) is inserted into the umbilical cord, this also appears in Paul's 3D animation. Sensors also measure the **insertion depth of the catheter between 2 and 8 cm** and display the current depth in a separate window that appears while the catheter is being inserted.

For scenarios beyond the immediate postnatal phase, when the umbilical cord has already fallen off, you will find an **belly button** in the box with the umbilical cords. If this is inserted, a belly button and no umbilical cord will appear in the animation on the user interface.



SIMCharacters Tip:

Umbilical arterial catheters (UAC) can also be inserted into the umbilical cord. However, these cannot be detected by the sensor system and cannot be advanced as deeply. In scenarios with an UAC already in place, the artery in the corresponding bubble must be activated manually. The arterial curve then appears automatically on the patient monitor.

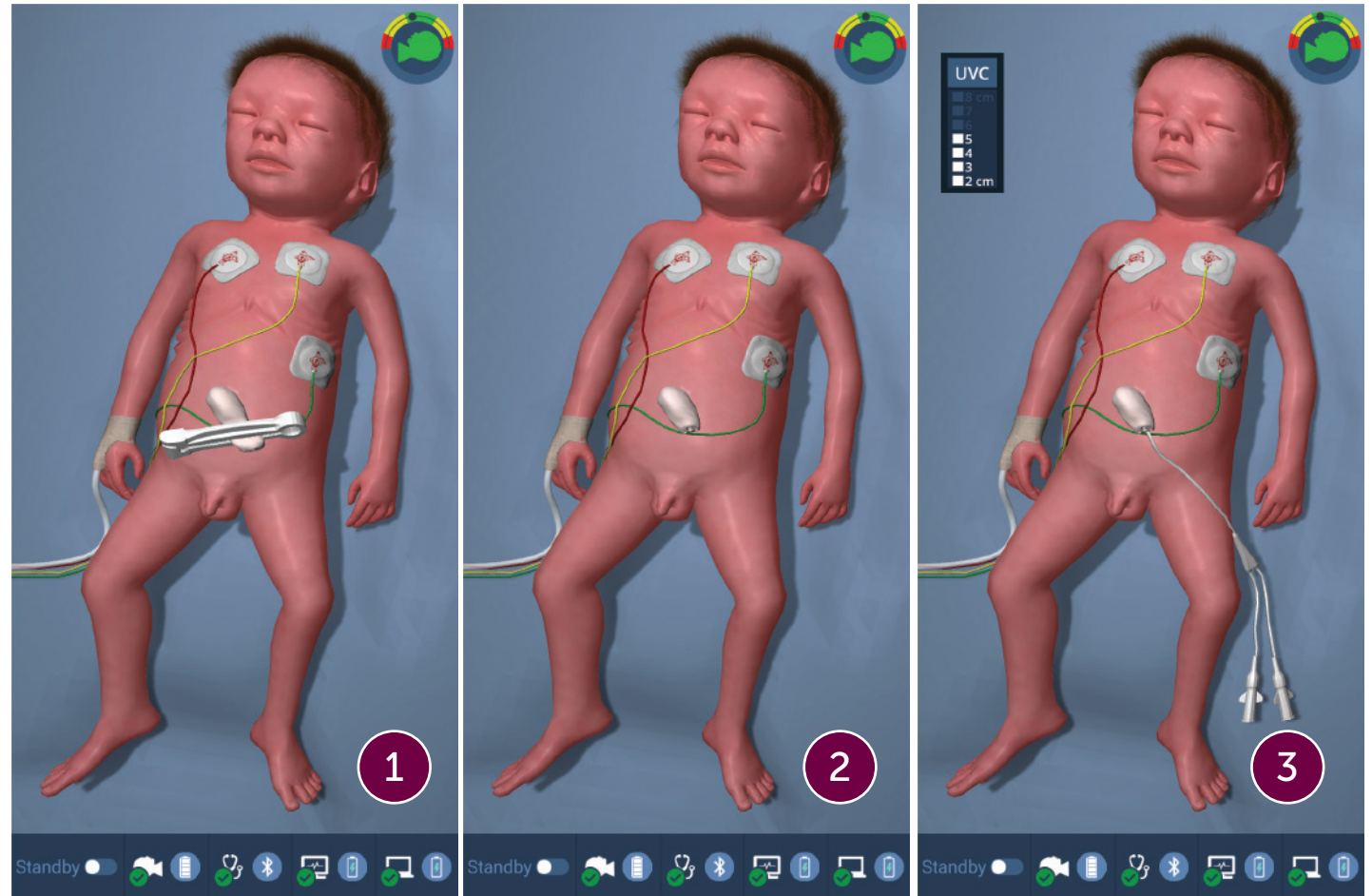

REPLACING THE UMBILICAL CORD

The umbilical cords are consumables. Paul is supplied with 20 umbilical cords.

The used umbilical cord is disposed of after the training scenario and replaced with a new umbilical cord.

To prevent the umbilical cord from accidentally coming loose during a training scenario, it is locked with the help of a locking mechanism during insertion.

1. To insert an umbilical cord or the belly button, it is advisable to first stop Paul's spontaneous breathing (AF=0).
2. The umbilical cord plug has an irregular shape. There is a red dot on the underside of the plug.
3. This red dot must point to the right belly side of Paul when the umbilical cord is inserted (note: red=right, 9 o'clock).
4. Now push the umbilical cord into the depths of the navel until it can no longer be pushed any further.
5. In this position, the umbilical cord can now be rotated 90° clockwise and finally locks into place at 12 o'clock.
6. **You can see whether the umbilical cord is correctly anchored when the umbilical clamp appears on the 3D animation of Paul.**
7. To remove the umbilical cord that was cut during training, the remaining umbilical cord stump must be turned 90° anti-clockwise again. The remaining umbilical stump can then be removed.



ATTENTION:

Never apply drugs or fluids into Paul's umbilical cord, as this can cause serious damage to the technology inside Paul. Should this ever happen accidentally, please switch Paul off immediately, do not switch him on again and contact our support team immediately (support@simcharacters.com).



UVC

- 0.5 cm
- 1 cm
- 2 cm

Indicators: RDS, BPD, NEC, Distension, PNX, Apnea

Vital Signs: HR 184, RR 35, SpO2 77%, Temp 37.5°C

RR	HR	UC PULSE	CO2	SpO2	SpO2 Post	NIBP	ART	TEMP
35	183	183	35	77%	77%	SYS 35	DIA 25	MAD 28

SCENARIO RUN

1	2	3	4
Training Setup	Training Setup	Training Setup	Training Setup
Start	Start	Start	Start
00:30	00:30	00:30	00:30

Status Bar: Standby, 00:00:00, MENU

PAUL'S FEATURES IN DETAIL

AUSCULTATION

Lung, heart and bowel sounds are not generated in Paul, but directly in the stethoscope. This prevents disturbing technical background noises during auscultation.

When the stethoscope is placed on Paul, sensors in Paul recognise the position of the stethoscope and the corresponding sound is played in the stethoscope; the sounds can be selected via drop-down menus on the GUI.

If a pre-programmed symptom complex is set, the corresponding sound is selected automatically. If Paul is auscultated by the training participants, the stethoscope also appears as an animation on the GUI and a corresponding event marker is transferred to the debriefing system.



SIMCharacters Tipp:

Auscultation is always a bit tricky with simulators. In version 2.0 of Paul, the area of the thorax and abdomen over which auscultation can be performed has been significantly increased. If your training participants still try to auscultate in an area that is not covered by the sensors, they will not hear anything. To prevent the participants from "making up" their own sounds in the scenario, you can recognise that they are not hearing anything when the stethoscope does not appear on the user interface and you can help them.

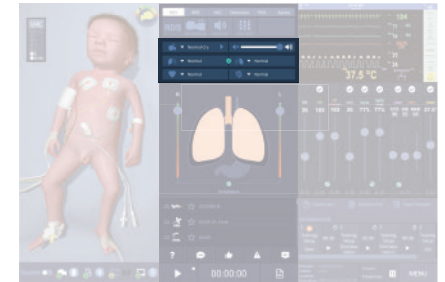



PAUL'S FEATURES IN DETAIL

SYMPTOM COMPLEXES

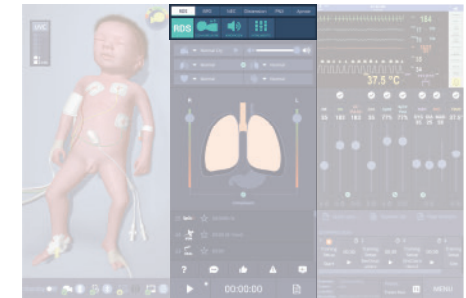

Paul deliberately not possess pre-programmed scenarios, but rather several pre-programmed symptom complexes (Respiratory Distress Syndrome (RDS), Bronchopulmonary Dysplasia (BPD), Necrotizing Enterocolitis (NEC), Abdominal Distension, Pneumothorax (PNX), and Apnea), which can be accessed in the middle to upper area of the user interface.

RESPIRATORY DISTRESS SYNDROME (RDS) AND BRONCHOPULMONARY DYSPLASIA (BPD)

Paul enables the simulation of typical symptoms of respiratory distress syndrome (RDS) in premature infants. Clinically, RDS manifests as paradoxical chest and abdominal movements, subcostal retractions, and abnormal respiratory sounds (grunting, wheezing). Bronchopulmonary dysplasia (BPD) is a chronic lung disease of premature infants, especially after prolonged mechanical ventilation. Clinical symptoms include tachypnea, increased respiratory effort, and fluctuations in oxygen saturation.

The symptom complex „**RDS**“ in Paul includes the symptoms of paradoxical breathing, subcostal retractions, and abnormal respiratory sounds (grunting, wheezing). Clicking the „**RDS**“ button activates all symptoms simultaneously. Additionally, lung compliance automatically decreases to approximately 75% of the maximum value.

The „**BPD**“ symptom complex includes increased respiratory effort, a decrease in oxygen saturation, and an automatic reduction of lung compliance to 85% of the baseline value.

By clicking on individual symptom buttons, all symptoms can also be selected individually for both symptom complexes.

RDS

**SEESAW BREATHING AND RETRACTIONS**

When „**Seesaw breathing**“ is activated either separately or through the „**RDS**“ menu, spontaneous breathing automatically switches to paradoxical breathing. Now, during inspiration, the chest moves inward while the abdomen moves outward significantly. This creates the impression of subcostal retractions as well. Seesaw breathing is also visually represented in the 3D animation of Paul on the user interface.

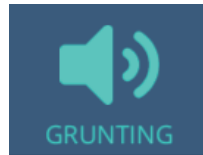
**GRUNTING**

If „**Grunting**“ is activated, respiratory distress syndrome sounds can be heard via Paul. The „**Grunting**“ can always be heard during expiration. If the breathing rate is changed, the grunting sounds also change according to the new breathing rate.

**VITAL SIGNS**

If you activate all RDS symptoms via the main „**RDS**“ button, Paul's vital signs will also change automatically. If you want to set your own vital signs, activate „**Seesaw breathing**“ and „**Grunting**“ separately without activating the main „**RDS**“ button.

BPD

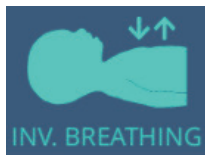
**SEESAW BREATHING**

When „**Seesaw breathing**“ is activated either separately or through the „**BPD**“ menu, spontaneous breathing also automatically switches to paradoxical breathing, albeit with a significantly less pronounced symptomatology. Lung compliance is reduced to 85%.

**VITAL SIGNS**

If all symptoms of BPD are activated via the main „**BPD**“ button, Paul's vital signs automatically change as well. Paul becomes tachypneic and experiences a drop in peripheral oxygen saturation. If you wish to set your own vital signs, activate „**Seesaw breathing**“ separately without activating the BPD button.

NECROTIZING ENTEROCOLITIS (NEC)

Necrotizing Enterocolitis (NEC) is a potentially severe intestinal disease in premature infants, characterized by mucosal and intestinal necrosis. It represents the most common gastrointestinal emergency in premature and newborn infants. The clinical presentation includes numerous findings such as lethargy, temperature instability, signs of ileus, a distended abdomen, occasionally livid discoloration of the abdomen, bilious vomiting, bloody stools, apnea, and general signs of sepsis. The diagnosis is made clinically and radiologically.

The „**NEC**“ symptom complex in Paul includes symptoms of a distended abdomen, livid discoloration of the abdominal skin, and a reduction in compliance. Clicking the main „**NEC**“ button activates all symptoms simultaneously. When the main „**NEC**“ button is clicked, the abdomen automatically protrudes and livid discolorations appear. Additionally, the vital parameters change automatically.

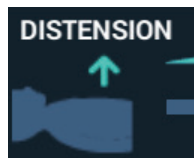

DISTENSION

When activated via the „**NEC**“ menu button, it automatically causes the abdomen to elevate. During manual operation, the intensity of the abdominal elevation can be freely adjusted using the slider. The **distended abdomen** is also visually represented in the 3D animation of Paul on the user interface.

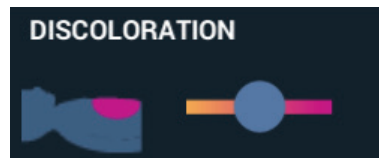

DISCOLORATION

If the „**Discoloration**“ is activated, several livid discolorations appear over Paul's abdomen. With manual control, the intensity of these discolourations can also be changed.



VITAL SIGNS

If you activate all symptoms of necrotizing enterocolitis using the main „**NEC**“ button, Paul's vital signs automatically change (drop in oxygen saturation, tachycardia, reduction in compliance). If you want to set your own vital signs (and compliance), activate „**Distension**“ and „**Discoloration**“ separately.



ABDOMINAL DISTENSION

The „**Distension**“ symptom complex solely involves distension of the abdomen without additional NEC signs (e.g., skin discoloration). A distended abdomen is a very common symptom in premature infants and can indicate difficulties with feeding as well as signs of gastric distension during non-invasive ventilation (CPAP) or mask ventilation.

The „**AUTO Distension**“ mode also allows for automatic filling of the stomach with air during inadequate mask ventilation and automatic reduction of compliance, compressing the lungs due to increased intra-abdominal pressure.

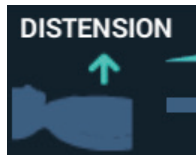

DISTENSION

The slider can be used to manually regulate the intensity of the abdominal distension and simulate a distended abdomen.



AUTO DISTENSION

When the „**AUTO Distension**“ program is activated, during head hyperextension under ventilation, there is a gradual filling of the stomach with air. This can be observed on Paul and on the user interface. As the stomach fills with air, Paul's abdomen becomes more distended. At the same time, lung compliance automatically decreases with each inadequate ventilation. Eventually, the abdomen becomes maximally distended. If the training participants suction the stomach, Paul's stomach can also be manually deflated using the „**Deflate**“ button.



Custom Presets

If you are editing the current preset (highlighted green), all changes are being applied immediately, without any other necessary action. If you are editing any other preset, you need to press the Update button in the bottom right corner of the screen to send the updated preset to Paul..

Preset Paul

+ Add New Copy Delete Name

Preset new7

Preset new6

Preset new5

Preset new4

Preset new3

Preset new2

HEAD POSITION



TIDAL VOLUME



CHEST MOVEMENT



PULSE STRENGTH



Optimal Tidal Volume CUSTOMISATION PRE-SETS

The optimal tidal volume for Paul with a weight of 60kg is determined with 4-8ml (green range). Here you have the

Show more ...

Paul comes with presets for the optimum head position, the optimum tidal volume, preset chest raises corresponding to the tidal volume and preset pulse strengths. However, you can customise these settings in the „pre-sets“ according to your own needs or the needs of your training participants.

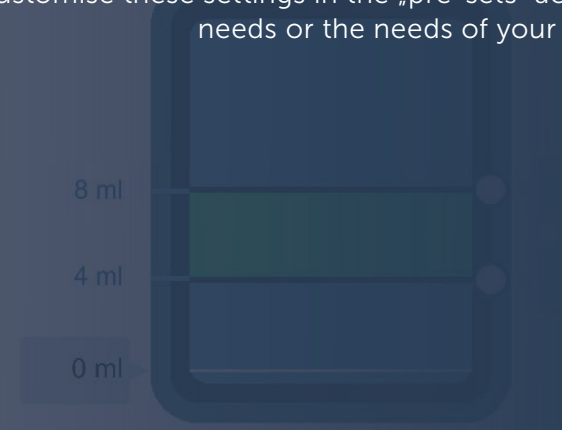

Default Ventilation

HEAD POSITION

The effectivity of ventilation is determined by Paul's head position. If Paul's head is in the neutral position (green segment), he can be ventilated optimally. With increasing flexion or hyperextension of the head (yellow segment), the probability of airway obstruction increases. With maximum flexion and maximum hyperextension (red segment), the airway is completely blocked.

The green, yellow and red segments are preset. However, you have the option of adjusting or adapting these segments according to your needs. Use the round sliders (white circles) to drag them and limit the boundaries of the green, yellow and red segments.

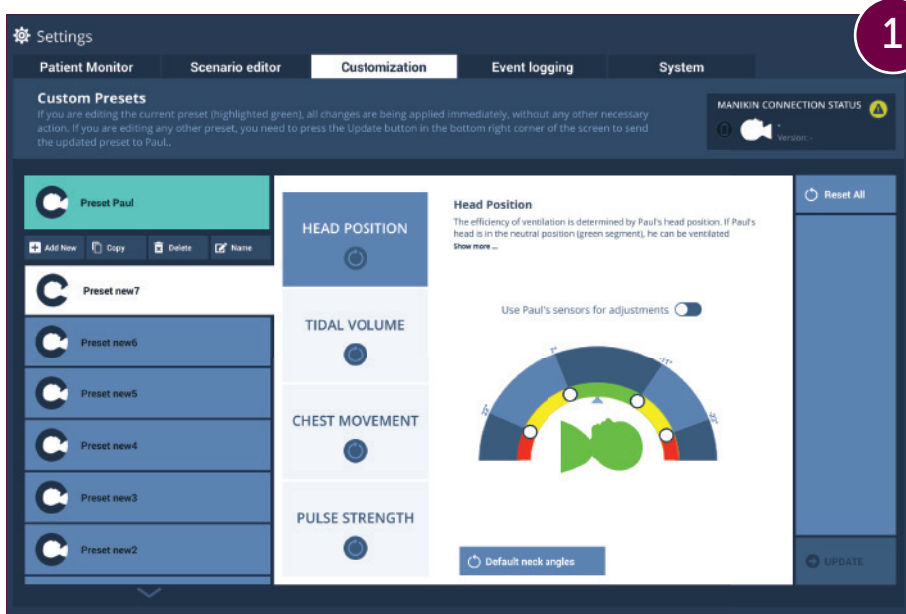

You can also set the segments directly with Paul. Click on the slider you want to adjust and move Paul's head to the desired position. You will see the head movement in real time on the user interface and can move the slider to the corresponding position. Click on the slider again and the new position will be saved and automatically transferred to Paul.

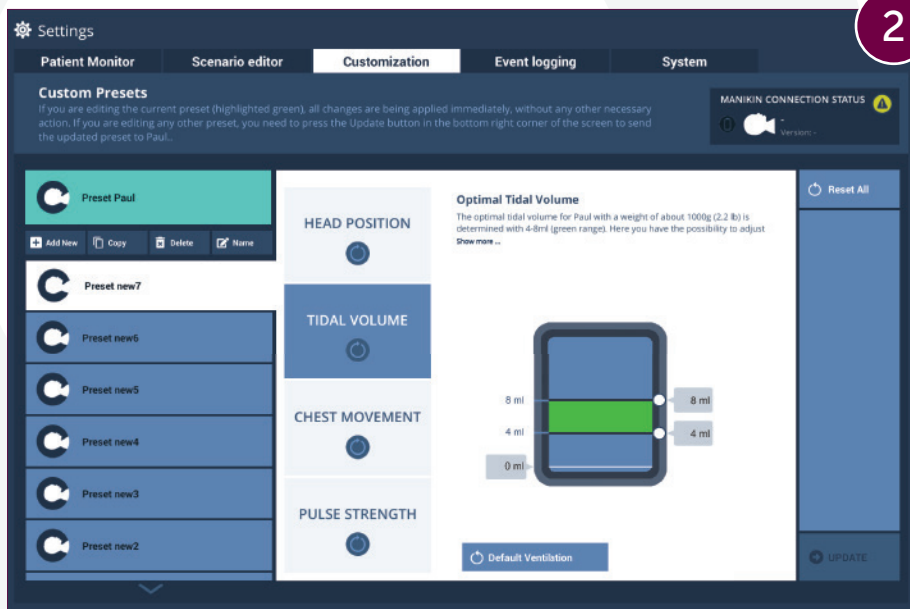

2

TIDAL VOLUME

The **optimum tidal volume** for Paul (approx. 1000g body weight) is set at **4-8ml** (green area).

You can adjust the range for the optimum tidal volume to your needs by moving the two sliders on the right-hand side of the display for the lower and upper limit to the desired position.

The yellow and red areas are calculated automatically. The new settings are saved and automatically transferred to Paul.

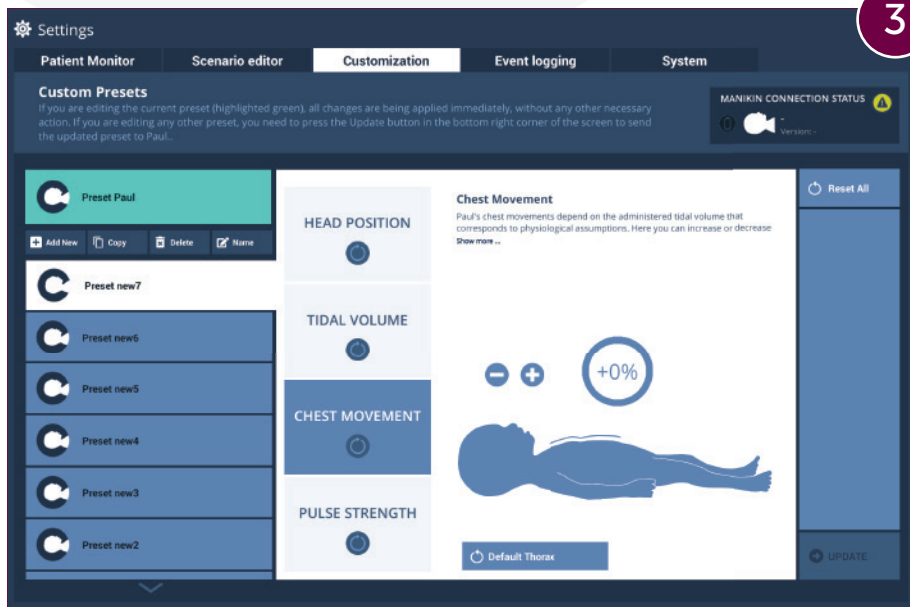

3

CHEST MOVEMENT

Paul's chest movements depend on the tidal volume with which Paul is ventilated.

The default setting corresponds to physiological assumptions. You can increase or decrease the amount of visible chest movement during ventilation according to your own needs or the needs of your training participants.

Click on +/- to increase or decrease the chest movements in 10% increments.

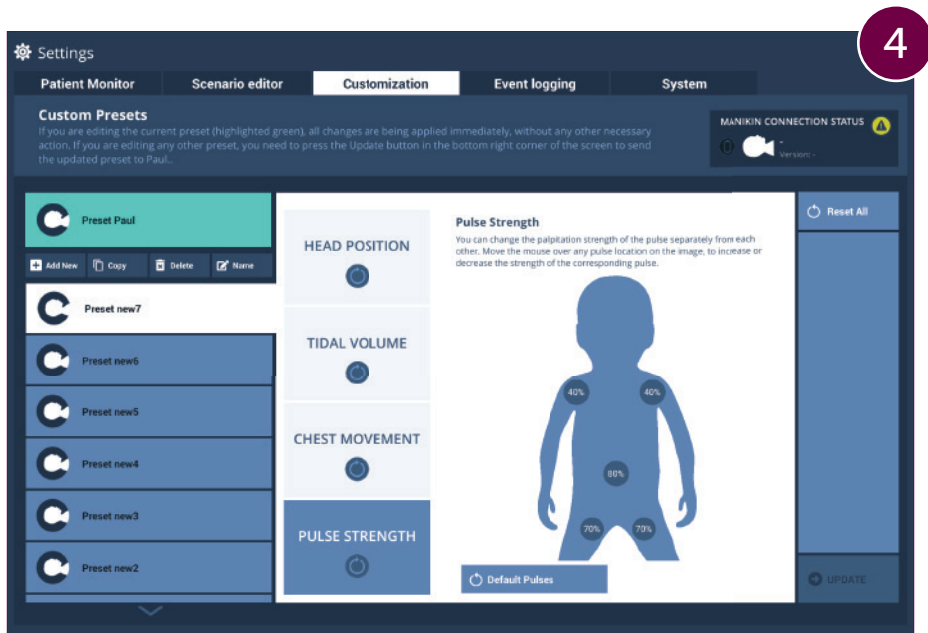

PULSES

The pulse strength of all five pulses (brachial, umbilical cord and femoral pulses) can be adjusted independently of each other in the pre-settings.

Click on any pulse in the graphic to increase or decrease the strength of the corresponding pulse.

The settings are automatically saved and transferred to Paul.

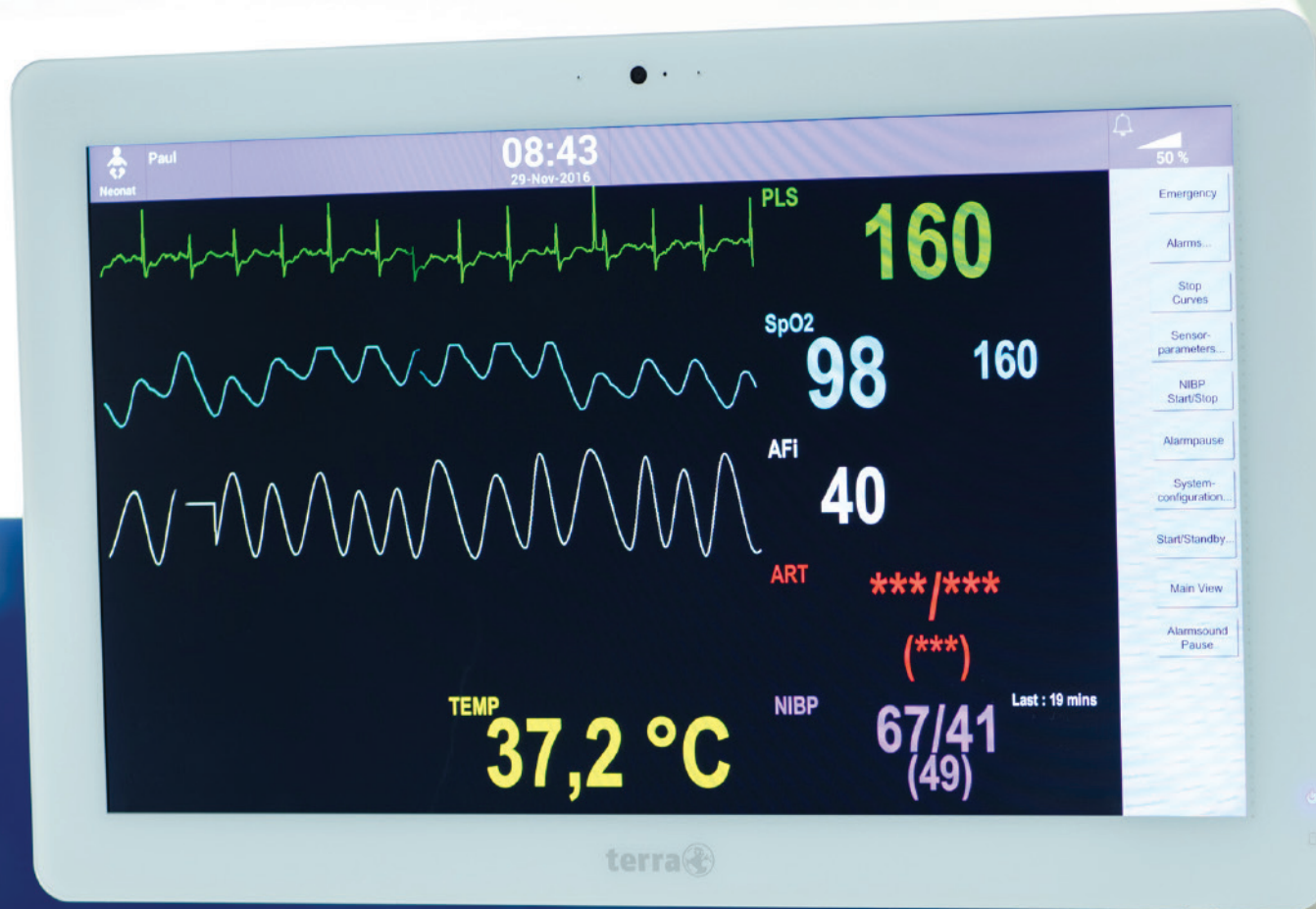

THE PATIENT MONITOR

The simulation system is equipped with the most common monitor types used in neonatology in order to provide the training participants the most realistic training possible.

The following monitor types can currently be selected:

- Dräger Infinity Series (1)
- Philips IntelliVue Series (2)
- GE B40
- Nellcor Pulsoximetry



The different monitors are displayed via the „Settings“ menu and can be selected here. By clicking on the corresponding monitor, the selected monitor is displayed on the trainer monitor and the participant monitor.

Settings

Patient Monitor | Scenario editor | Customization | Event logging | System

Current Patient Monitor
This is how the Patient Monitor will be displayed for your trainees. You can choose from different layouts on the right. Common settings like alarms, colors and volume are shared between all monitors.

Paul
Neonat | 13:03 PM
17-May-2024 | 50 %

PLS **159**

SpO2 **98** 160

ART **35/25 (28)**

RR **35**

TEMP **37.5 °C**

NIBP *****/***** Last: **(***)**

- Emergency
- Alarms...
- Stop Curves
- Sensor-parameters...
- NIBP Start/Stop
- Alarm pause
- System configuration...
- Start/Standby...
- Main View
- Feedback Monitor

Draeger Infinity C700

Philips IntelliVue MX700

MX700 Large Values

Covidien Nellcor

GE B40

Feedback Monitor

CONFIGURATION OF THE PATIENT MONITOR (BY THE TRAINERS)

To enable simple configuration, this is carried out as usual through the menu navigation of the corresponding monitor type. The trainers can make all settings such as curve arrangements, curve colors and alarm limits here. The changes also appear immediately on the vitality monitor in the training area.

Settings

Patient Monitor | Scenario editor | Customization | Event logging | System

Current Patient Monitor
 This is how the Patient Monitor will be displayed for your trainees. You can choose from different layouts on the right. Common settings like alarms, colors and volume are shared between all monitors.

Paul | 02:27 AM | 26-Apr-2024 | 50%

Parameter	Alarm	Lower	Current	Upper
HR beats/min	⚠	100	175	170
RR /min	⚠	30	49	60
SpO2 %	⚠	88	91	98
SpO2Post %	⚠	88	92	98
PLS /min	⚠	100	175	170
PLS Post /min	⚠	100	179	170
NIBP S mmHG	⚠	30	33	40
NIBP D mmHG	⚠	20	23	30
NIBP M mmHG	⚠	20	23	30
ART S mmHG	⚠	30	35	40
ART D mmHG	⚠	20	25	30
ART M mmHG	⚠	20	28	30
Temp °C	⚠	37	37.5	37.7
etCO2 mmHG	⚠	30	34	98

Alarms | Alarm boundaries | Settings

PLS: 175
 SpO2: 91 | 175
 RR: 49
 °C: 37.5
 NIBP: ***/***/ (***)

Emergency | Alarms... | Stop Curves | Sensor-parameters... | NIBP Start/Stop | Alarm pause | System configuration... | Start/Standby... | Main View | Feedback Monitor

Draeger Infinity C700
 Philips IntelliVue MX700
 MX700 Large Values
 Covidien Nellcor
 GE B40
 Feedback Monitor

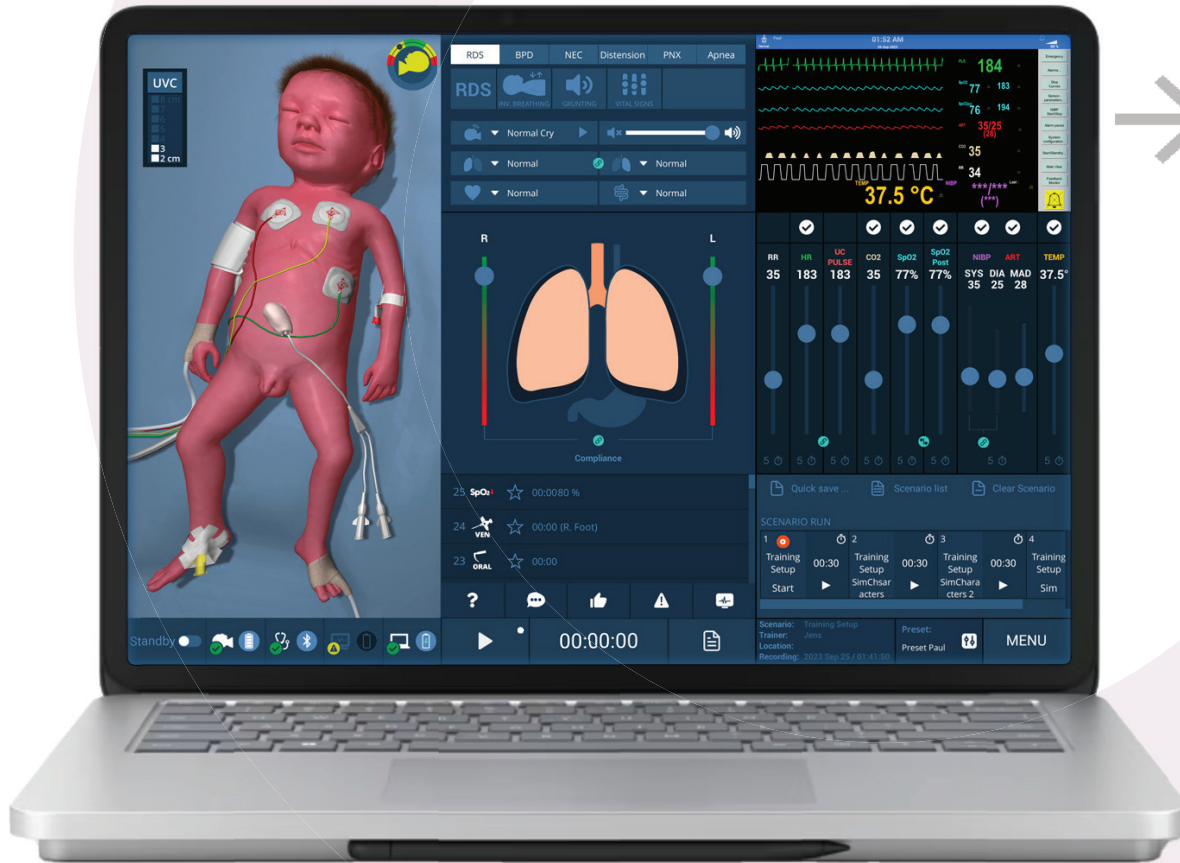

CONTROL OF THE PATINET MONITOR (BY THE TRAINERS)

The Vitalmonitor is controlled via the „mixer“ on the user interface.

The corresponding parameter is set by dragging the controls. This can be done via the touchscreen surface of the trainer monitor, with a mouse or via the trackpad. The small clock at the bottom of the respective slider can be used to freely select the time over which the parameter is to be changed to the new value.

The following vital parameters can be set:

1. Respiratory Rate
2. Heart Rate
3. Umbilical Pulse
4. Endtidal CO₂
5. Preductal peripheral saturation
6. Postductal peripheral saturation
7. Non-invasive Bloodpressure
8. Invasive Bloodpressure
9. Temperature

A parameter is released to the participant monitor either via the input bubbles above Paul or directly by clicking on the tick at the top of the corresponding parameter.

If the tick lights up white, the curve or value appears on the trainer and participant monitors.

Trainers and participants therefore always see the same monitor status. This is to prevent people from getting to release curves.

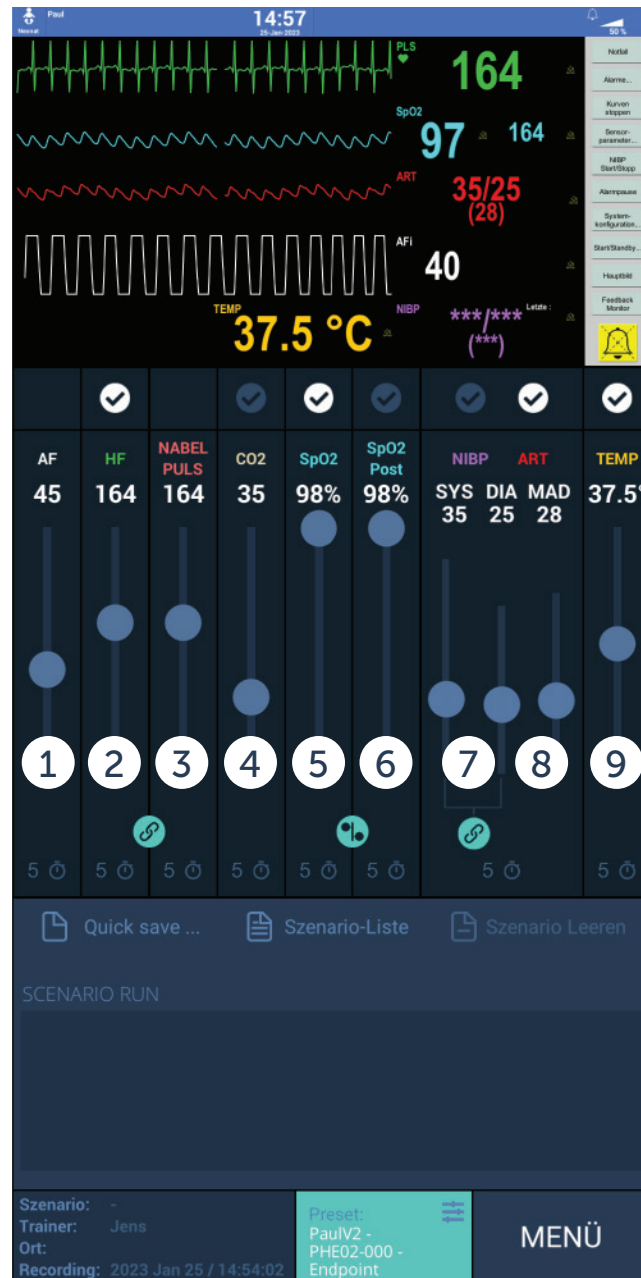

OPERATION OF THE PATIENT MONITOR (BY TRAINING PARTICIPANTS)

By selecting the appropriate monitor type, training participants can make settings on the patient monitor, such as setting alarm limits, acknowledging alarms or setting automatic blood pressure measurement intervals, using the familiar user interface of their monitor type.

The patient monitor has a touchscreen interface. When the simulation system is started, the monitor is in standby mode. By touching the interface, the individual areas for the vital parameters and curves will appear. Settings can now be made. As soon as the corresponding values and curves have been activated by the trainer, they will appear on the monitor in real time.

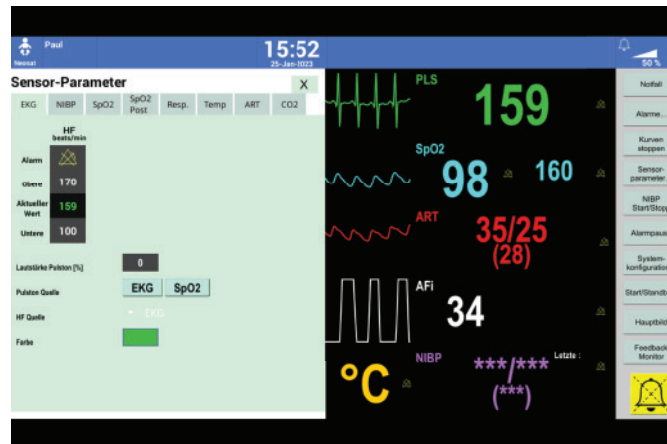
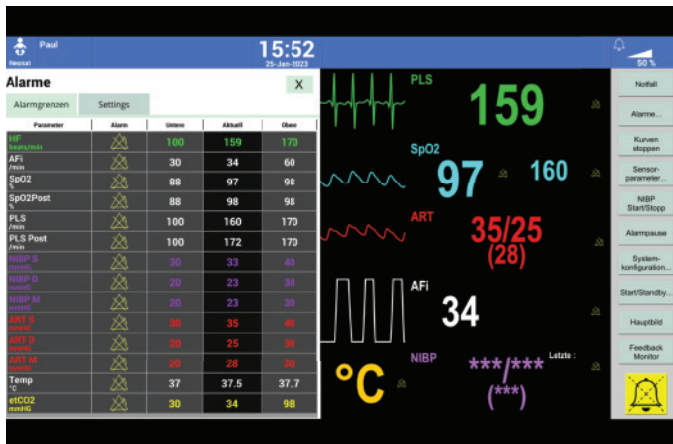
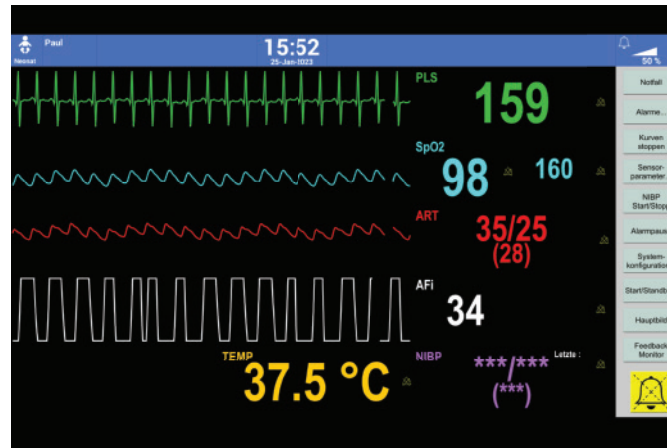
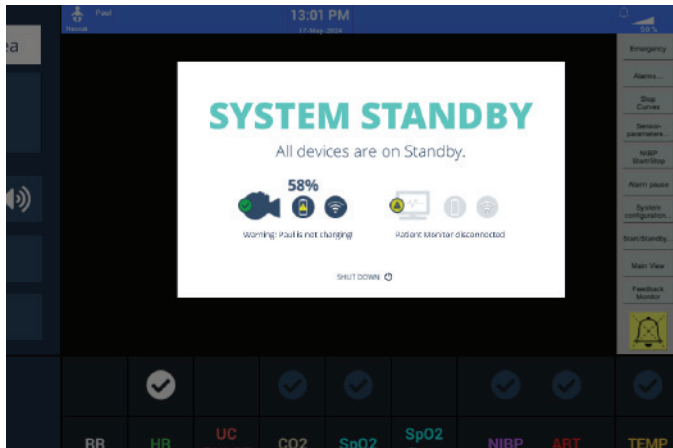

59
Mischer



Neonat Paul

08:40
29-Nov-2016

50%

Sensor-Parameters

- EKG
- NIBP
- SpO2
- Resp.
- Temp
- ART
- CO2

HF
beats/min

Alarm

Upper 105

Current Value 159

Lower 70

Volume Pulse sound [%]

Pulse sound source EKG SpO2

HF Source EKG

Color



- Emergency
- Alarms...
- Stop Curves
- Sensor-Parameters...
- NIBP Start/Stop
- Alarmpause
- System-figuration...
- Standby...
- View
- Alarm sound Pause

Absaugung



AutoBreath™



Patientenbeatmung



Gasversorgung



FEEDBACK MONITOR

The feedback monitor is used during the orientation phase, which involves familiarizing the training participants with the simulator. When the feedback monitor is selected, it appears on the patient monitor in the training room. This mode allows participants to receive direct real-time feedback on their measurements regarding the current head position, tube position and depth during intubation, information about PIP (Peak Inspiratory Pressure), PEEP (Positive End-Expiratory Pressure), tidal volume, and ventilatory rate during ventilation, as well as the effectiveness of chest compressions. This enables highly effective familiarization and better preparation for the subsequent training scenarios.

CPR →

0
/min

0
%

PIP
cmH₂O

0

PEEP
cmH₂O

0

Rate
/min

0

Optimal
%

0

VT 0 ml

HEAD POSITION

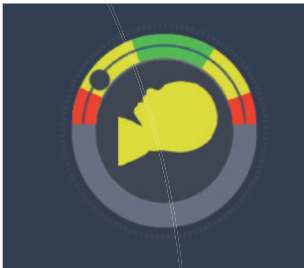

The sensor for head position displays Paul's current head position in real-time. The head position affects the effectiveness of ventilation. If the head is too flexed, Paul cannot be ventilated properly; if the head is too extended, there may be gastric ventilation, causing the abdomen to rise and fall during ventilation.
(see chapter „Ventilation“, p.32)

INTUBATION

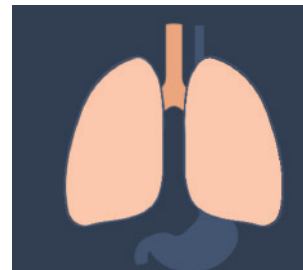

When Paul is intubated, the endotracheal tube appears either in the trachea or the esophagus accordingly. If Paul is intubated too deeply into the trachea, the right lung automatically collapses, and during ventilation, only the left side of the thorax rises.
(see chapter „Intubation“, p.34)

CHEST COMPRESSIONS

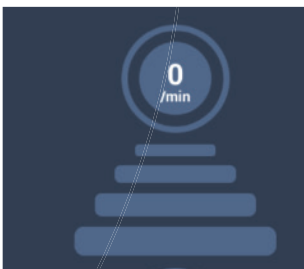

During chest compressions on Paul, the chest compression sensor indicates the effectiveness of the performed chest compressions. Additionally, it displays the compression frequency and the percentage of effective chest compressions.
(see chapter „Circulation“, p.37)

VENTILATION

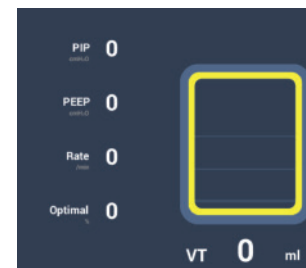

When Paul is being ventilated, the tidal volume, peak pressure, PEEP, and ventilation rate are displayed in this graph. This allows for optimal preparation for the training scenarios.
(see chapter „Ventilation“, p.33)

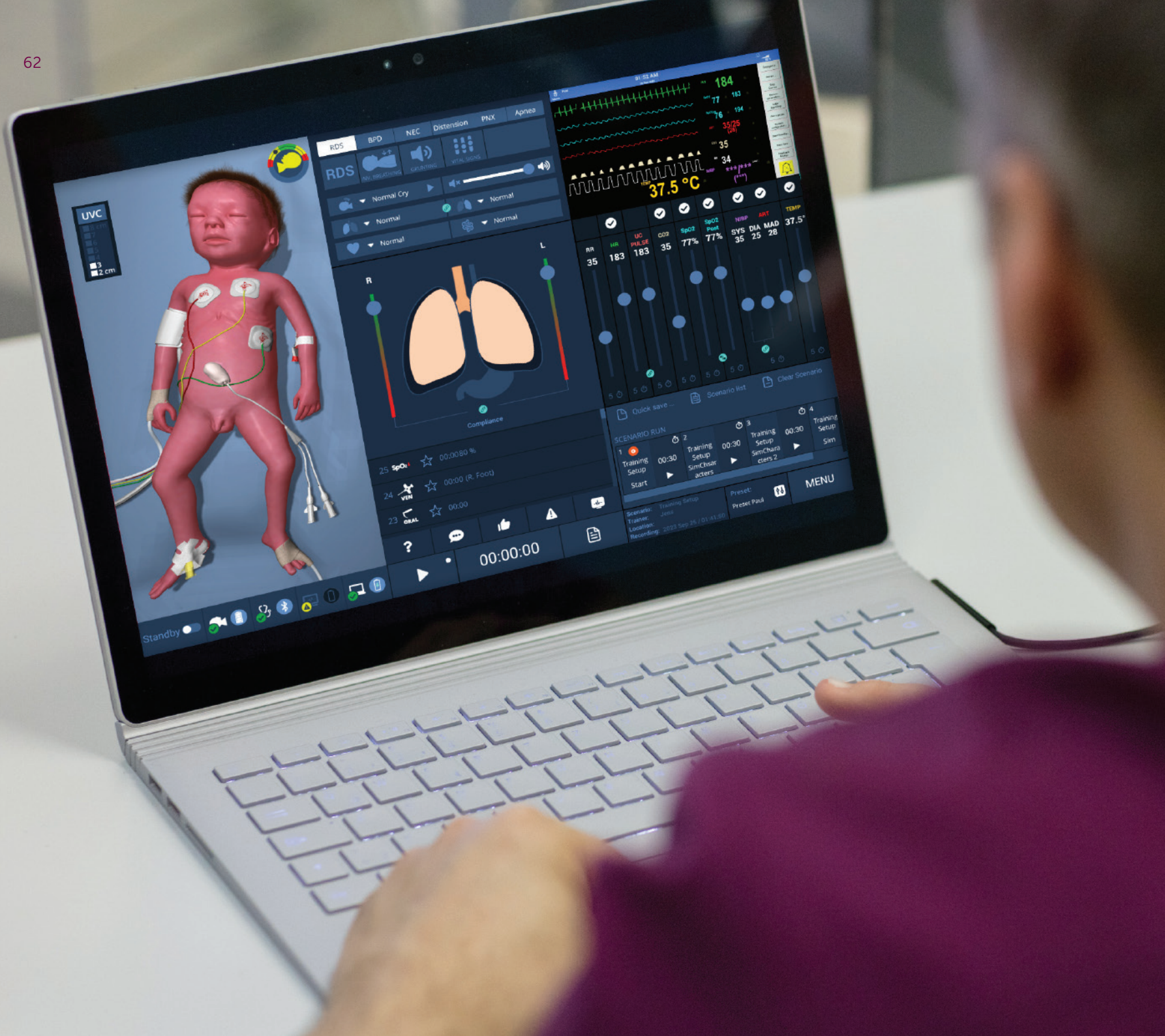

SCENARIO DESIGN

PRE-PROGRAMMING SCENARIOS

Paul's software makes it very easy to pre-programme initial scenario settings and scenario sequences in a standardised way and call them up again and again.

You can programme scenarios in two ways:

1. via the „Quicksave“ function or
2. via the scenario editor.

The **„Quicksave“** function can be used at any time to save the current status of the entire simulation system (Paul, vital parameters, monitor settings) can be saved at any time.

By stringing together several scenario stages and connecting them via a freely definable transition time from one stage to the next, entire scenario sequences can be programmed.

EXAMPLE

1 After setting the initial simulator settings, click on the **„Quicksave“** button.

The screenshot displays the Paul 2.0 simulation interface. On the left, a 3D model of a newborn baby is shown with various sensors attached. The central panel features a respiratory system diagram with 'R' and 'L' labels and a 'Compliance' control. The right panel shows vital signs: HR 159, SpO2 98, RR 97, PIP 26/16 (19), and Temp 37.5°C. Below these are sliders for AF (45), HF (160), NABEL PULS (160), CO2 (35), SpO2 (98%), SpO2 Post (98%), NIBP (26/16/20), and ART (20). A 'Quick save ...' button is highlighted with a red circle and the number '1'. The bottom status bar shows 'Standby', a timer at '00:00:00', and a 'MENÜ' button.

AF	HF	NABEL PULS	CO2	SpO2	SpO2 Post	NIBP	ART	TEMP
45	160	160	35	98%	98%	SYS DIA MAD 26 16 20	20	37.5°

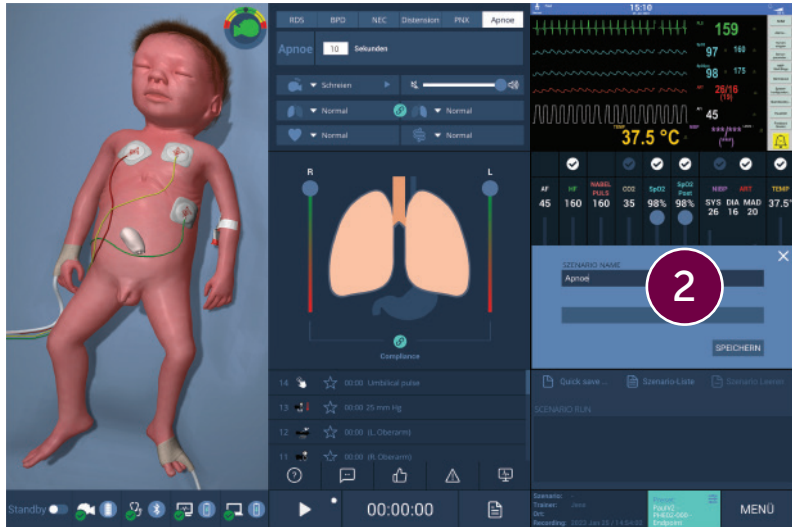

2 You can give the scenario a title, then click on „Save“.

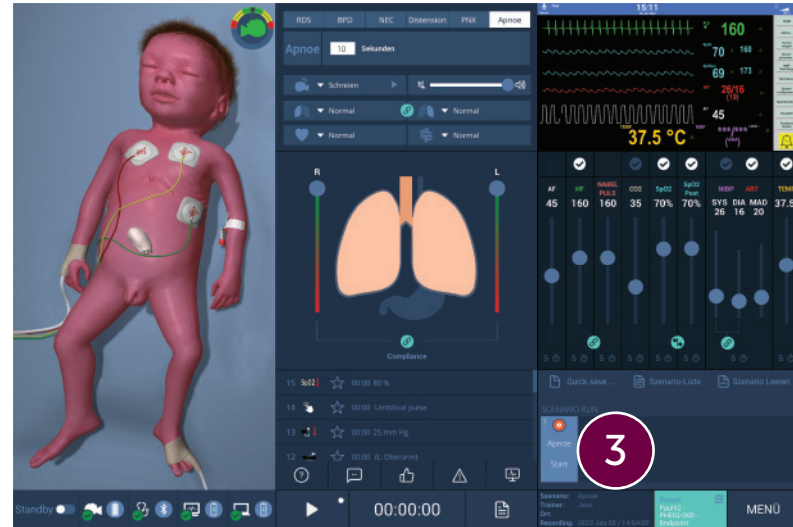

3 The first status is saved and appears in the „Scenario history“ area.

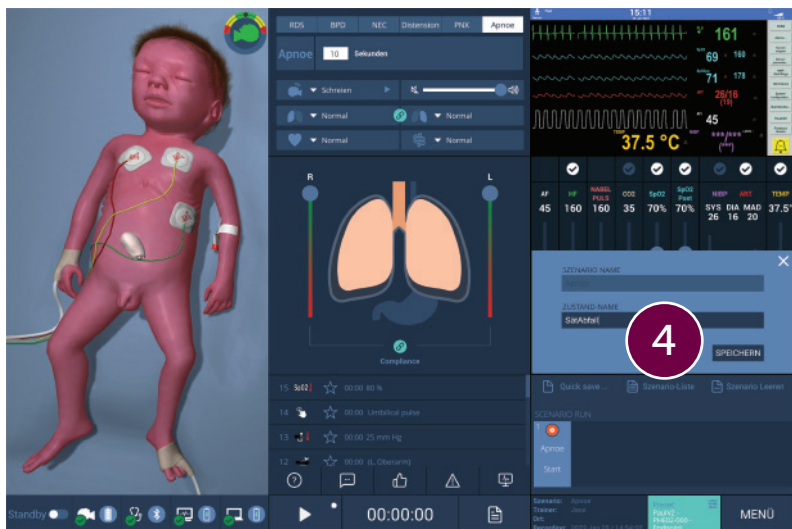

4 Then define the next scenario status and click on Quicksave again. In the window that opens, you can now enter a name for this status in the „Status name“ field.

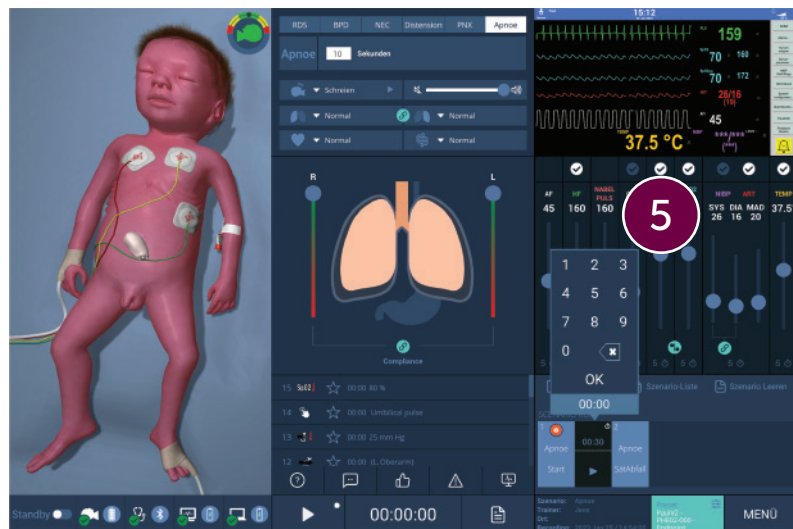

5 The second status is saved and a field now appears between the two stages in which you can select the transition time between the two stages.

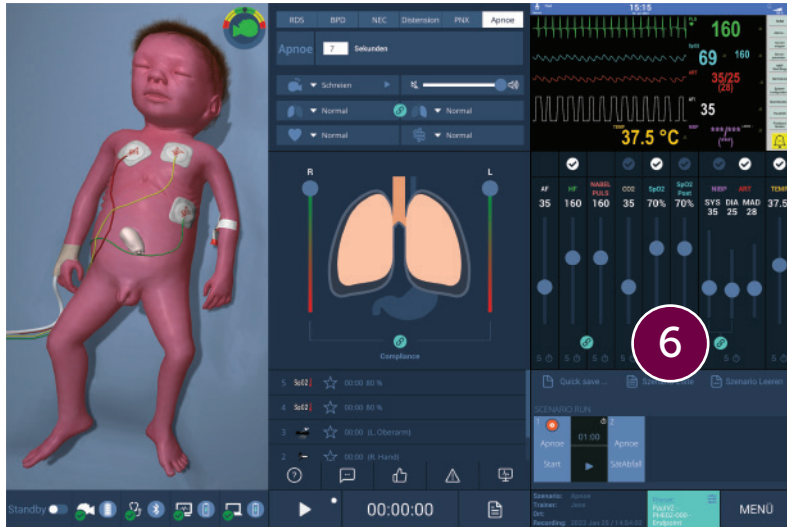

6 Then set the next status and click on Quicksave again.

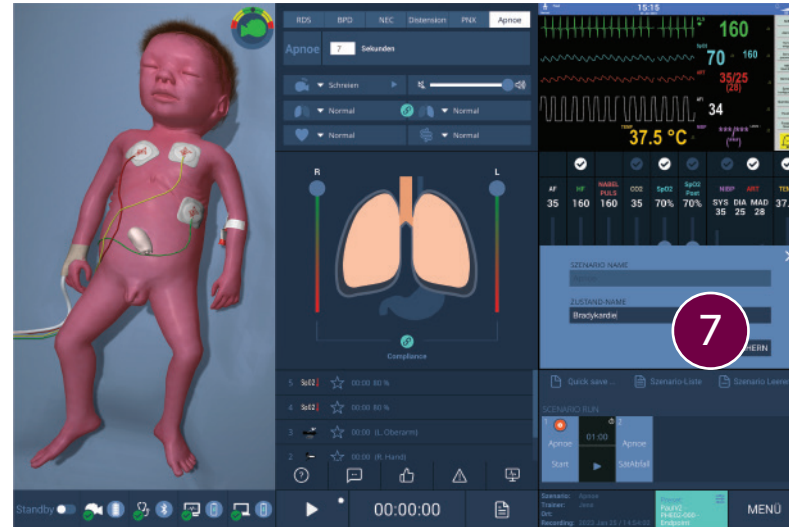

7 Enter a name for the new status again.

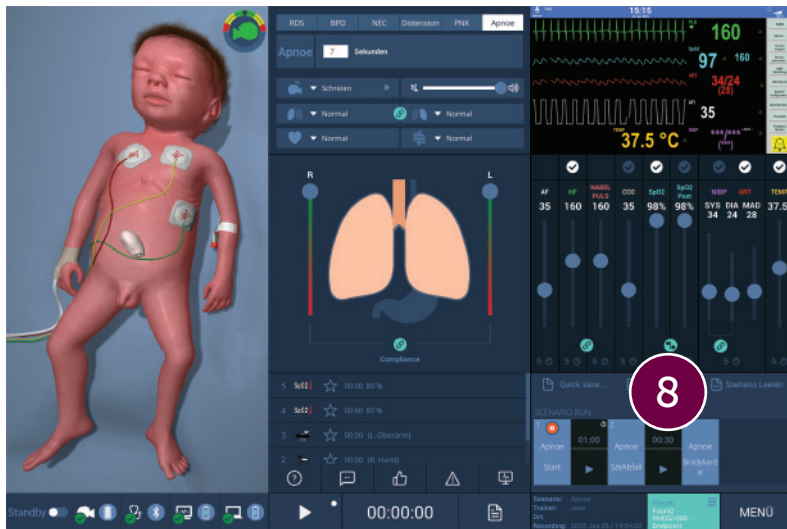

8 Choose a transition time.

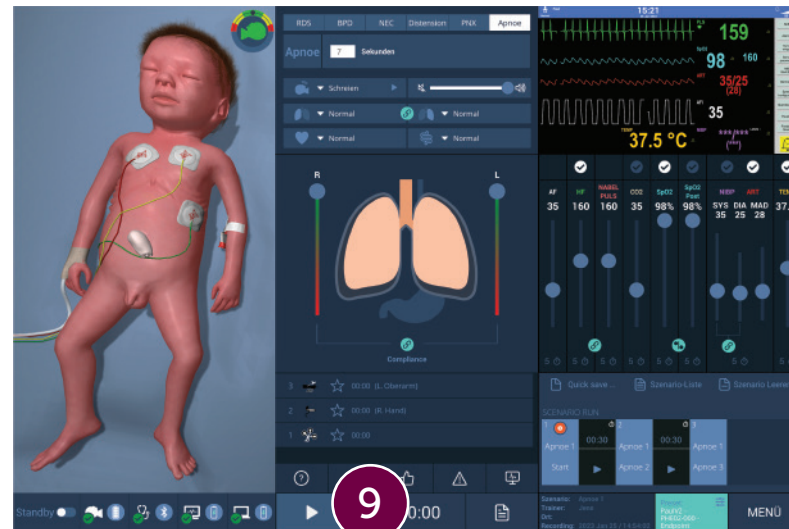

9 Repeat the steps as often as necessary and then start your pre-programmed scenario with the „Play“ button.

SCENARIO EDITOR

Alternatively, you can also programme scenarios in the scenario editor. You can find this under „**Menu > Settings**“. In the scenario editor you will find all your programmed scenarios and can also edit them there. You can also mark your own scenarios here with their own symbol and colour to make them easier to find.

In the „**Manikin preferences**“, you can generate checklists for the preparation of each scenario, which are then displayed on the patient monitor during the preparation of the scenario.

The screenshot shows the 'Settings' window with the 'Scenario editor' tab selected. The interface is organized as follows:

- Scenario Archive (Left):** A list of scenarios including Apnea, Adrenaline, Respirationshort, Respirationprolonged, CPR, healthyprematuurebaby, NEC, and PEEP.
- Scenario Editor (Center):**
 - NAME:** 'Apnea' with a color selection bar.
 - SCENARIO RUN:** A sequence of states: 'Apnea' (01:00), 'Cyanosis' (00:30), and 'Bradycardia'.
 - STATE NAME:** 'Start'.
 - PARAMETERS:** RDS, BPD, NEC, Distension, PNX, INV. BREATHING, GRUNTING, VITAL SIGNS, Normal Cry, Normal, and Compliance (RIGHT: 100 / 100, LEFT: 100 / 100).
- Patient Monitor (Right):** A panel showing vital signs and their sliders: RR (35), HR (160), UC PULSE (160), CO2 (35), SpO2 (98%), SpO2 Post (98%), NIBP (SYS 35, DIA 25, MAD 28), ART, and TEMP (37.5°).
- Buttons:** 'New State', 'Delete State', 'New...', 'Load Scenarios', 'Delete', 'Save As ...', 'Save', and 'Load this'.

START SAVED SCENARIOS

To start a saved scenario, select the desired scenario in the scenario editor and click on the **“Load scenario”** button. The individual stages now appear on the user interface in the **“Scenario run”** area. By clicking on the Play button in the Scenario run field, the scenario is started and the start status moves to the next stage according to the selected transition time. In this way, scenarios can be played again and again in a standardised manner. During a programmed scenario, you can intervene in the scenario process at any time; the scenario is then not continued. During the scenario, the progression can also be paused or accelerated or stages can be skipped.

The screenshot displays the SIMCharacters software interface, which is divided into several functional areas:

- 3D Model:** A realistic 3D rendering of a newborn baby lying down, equipped with various medical sensors and wires.
- Scenario Editor (Top Left):** A panel for configuring the current scenario. It includes tabs for different conditions (RDS, BPD, NEC, Distension, PNX, Apnoe) and a specific 'Apnoe' section where a duration of 7 seconds is set. There are also sliders for 'Schreien' (crying) and other physiological parameters.
- Vital Signs (Top Right):** A dashboard showing real-time data: PLS (159), SpO2 (98), ART (35/25 (28)), AFI (35), and TEMP (37.5 °C). A 'NIBP' section shows asterisks, indicating a specific blood pressure status.
- Physiology Diagram (Middle):** A simplified anatomical diagram of the baby's chest and lungs, with 'Compliance' controls for the right (R) and left (L) sides.
- Scenario Run (Bottom Right):** A control panel for executing saved scenarios. It features a 'SCENARIO RUN' section with a sequence of stages (Apnoe 1, Apnoe 2, Apnoe 3) and a 'Start' button. Below this, there are 'Quick save...', 'Szenario-Liste', and 'Szenario Leeren' options.
- Bottom Bar:** A navigation and status bar containing a 'Standby' toggle, various system icons, a play button, a timer set to 00:00:00, and a 'MENÜ' button.

DEBRIEFING SYSTEM

A debriefing system is already integrated into Paul's user interface. It is controlled in the lower center area of the user interface.

STARTING A TRAINING SCENARIO

When you start a scenario using the play button in the debriefing system, a clock starts to run automatically.

All of Paul's sensor data (e.g. ventilation, intubation, placing a UVC) and the events set by the trainers (e.g. ECG, saturation, access) are now given a time stamp and automatically transferred to the debriefing system. In the debriefing window of Paul's user interface, you can now always see the last three events and can also comment on them using the comment function (via the pencil icon on the right-hand side of each individual event field).

At the same time, you can set markers, e.g. for the assessment of non-technical skills (such as communication and teamwork) and also comment on these. You can also use the monitor icon in this bar to create a screenshot of the currently displayed vital data and use it in the debriefing.

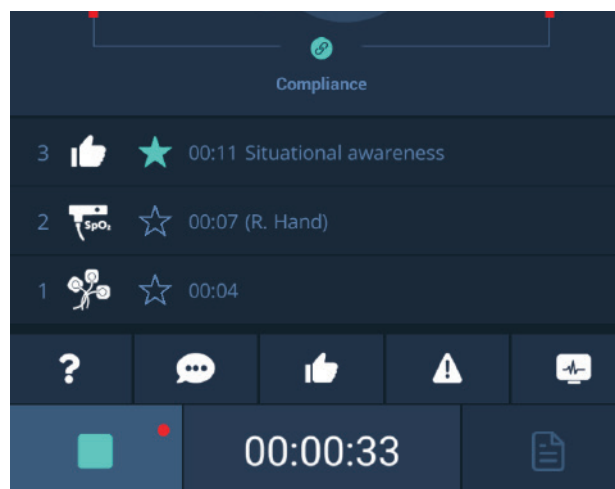
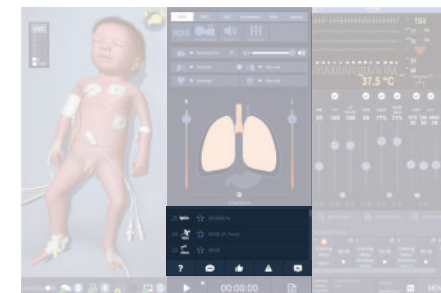

SIMCharacters Tip:

The small asterisk between the event icon and the timestamp allows you to mark an event that you consider particularly important for the debriefing during the training scenario.

ENDING A TRAINING SCENARIO

You can stop recording events using the „**Stop**“ button. When you click on the Stop button, you will first be asked again whether you really want to end the training. You can then give the scenario a name, add comments and save the scenario.

Before you go to the debriefing, you will be reminded once again to connect Paul to the charging cable or place him on the charging pad. The whole system will then automatically go into standby mode.

Clicking on the debriefing symbol takes you to debriefing mode. Here you will find all your scenarios. By clicking on the desired scenario, the scenario opens and you can see all your set markers and automatically generated events.

Scenario Run		BACK
Date:	24 Apr 2024 02:39	
Name:	Res1	
Scenario:	-	
Trainers:	Jens	
Location:		
1	00:00	01:41
2	00:00	01:50 nsk richten
3	00:09	02:19
4	00:18	02:26
5	00:30	02:28 Effektivtaet
6	00:34	03:13 0.1ml Adrenalin
7	00:40 kopf	03:20 Sit awareness Pflgepl
8	00:52	03:44 (R. Hand)
9	01:09	03:57 Stop Thoraskompressionen
10	01:17	

COUNT	TIME	DESCRIPTION
01	00:00	
02	00:00	
03	00:00	
04	00:18	
05	00:30	
06	00:34	
07	00:40	kopf
08	00:52	
09	01:09	
10	01:17	
11	01:41	
12	01:50	nsk richten
13	02:19	
14	02:26	
15	02:28	Effektivitet
16	03:13	0.1ml Adrenalin
17	03:20	Sit awareness Pflgepl
18	03:44	(R. Hand)
19	03:57	Stop Thoraskompressionen



SIMCharacters Tip:

All recorded scenarios are automatically saved on the desktop in the „**Debriefings**“ folder as Word, Excel and PDF documents saved.

CARE, STORAGE & MAINTENANCE

BEFORE EVERY TRAINING

Please put a few drops of the silicone oil provided in both nostrils and in Paul's mouth before each training session. Intubate Paul several times before each training session using a tube moistened with the care oil supplied. **Please only use the care oil supplied by SIMCharacters!** Not using care oil makes intubation difficult and can lead to damage to the airways. At the same time, the airways are maintained and retain their elasticity. The silicone oil does not need to be removed from the airways after training.

DURING EVERY TRAINING

Temperatures higher than 30° Celsius during operation should be avoided, as the additional heat generated can damage the simulator's electronics. Therefore, please switch off heat lamps, incubators, etc. during training.

AFTER EVERY TRAINING

The simulator is splash-proof but not waterproof. If Paul gets wet during training, please dry him thoroughly with a dry cloth. Then clean Paul with a water-based baby wipes and put him back in the sleeping bag provided. To protect his head and hair, please put his hat back on.

STORAGE

Store the simulator in a cool and dry place.

GENERAL MAINTENANCE

If Paul is not used for a longer period of time, please fully charge the battery once every 90 days to avoid damaging the battery.



At the end of each training session, please make sure that Paul has completely shut down. You can recognise this by the fact that the light on Paul's stomach has switched off completely. If it is still lit and you have already switched off the computer or router, you can switch Paul off manually by stroking Paul's head several times with the magnet provided.

WE CARE FOR YOUR PAUL!

WARRANTY EXTENSION & CARE PROGRAM TO 2 YEARS

- Extends your included 1 year standard warranty to 2 years with system guarantee on all parts and labor.
- Includes 1 preventive maintenance return of your Paul systems for complete refurbishment.
- Repair completed at our facilities with all shipping costs and handling costs covered.
- If necessary, ready-to-use replacement system promptly shipped to your institution if your system malfunctions for any reason or if product is required during refurbishment period.
- Free system updates.

WARRANTY EXTENSION & CARE PROGRAM TO 5 YEARS

- Extends your included 1 year standard warranty to 5 years with system guarantee on all parts and labor.
- Includes 2 preventive maintenance returns of your Paul systems for complete refurbishment.
- Repair completed at our facilities with all shipping and handling costs covered.
- If necessary, ready-to-use replacement system promptly shipped to your institution if your system malfunctions for any reason or if product is required during refurbishment period.
- Free system updates.

SIMCharacters Support:

E-Mail: support@simcharacters.com

Phone.: +43 1 581 20 94



REMOTE SUPPORT

1. ETHERNET CABLE CONNECTION

WIRED CONNECTION APPROACH

In order for the support team to be able to remotely access your trainer monitor and Paul, your devices need to simultaneously be connected to the Paul Network and the Internet. That can be done through an Ethernet Cable. Just connect Paul's router with a router that has access to the internet. The Ethernet Cable has to go in the port labeled "1 – Internet" in order for the connection to be successful. Follow the instructions on the solution design below.

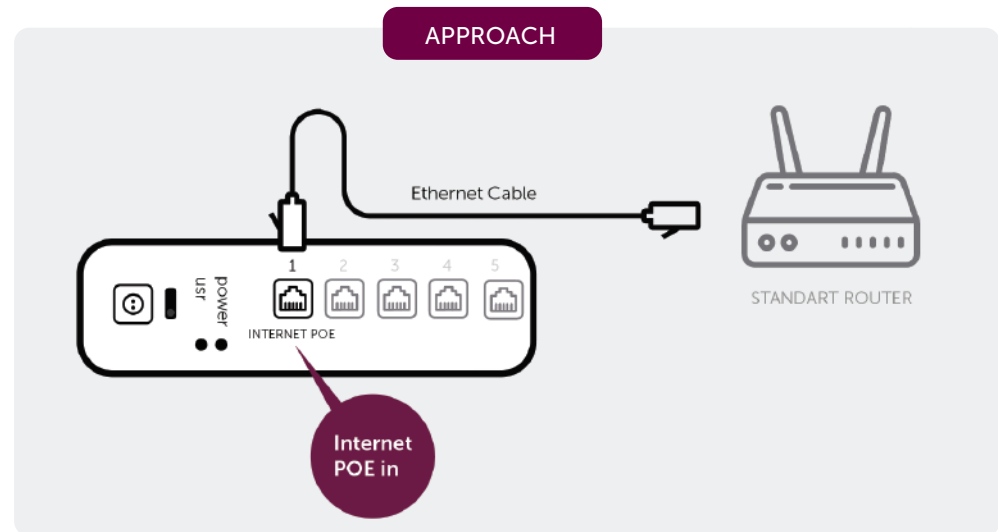
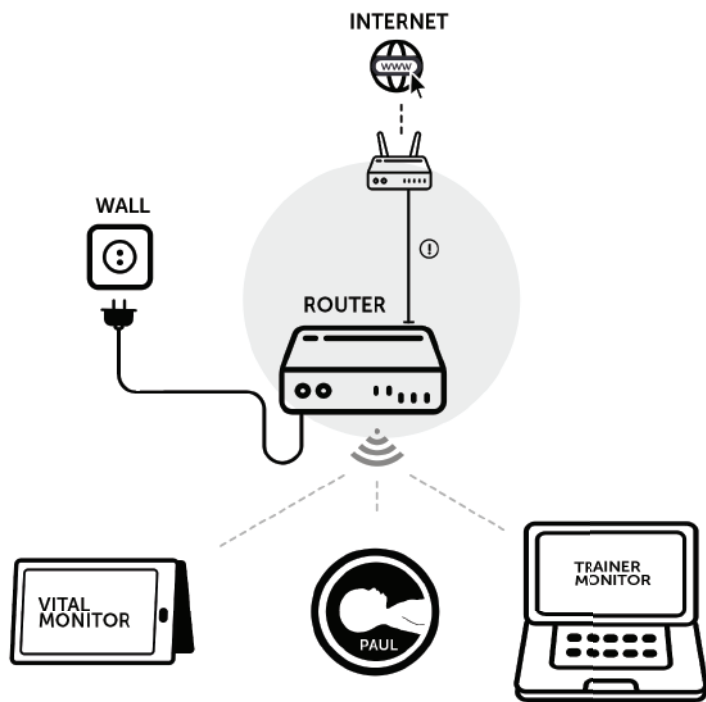

2.WIFI ADAPTER CONNECTION

WIFI-ADAPTER APPROACH

In order for the support team to be able to remotely access your trainer monitor and Paul, your devices need to simultaneously be connected to the Paul Network and to the Internet. That can be also done through a USB-WIFI Adapter. That ensures that the trainer monitor stays connected to the Paul Network, whilst being connected to the Internet. Like displayed on the design

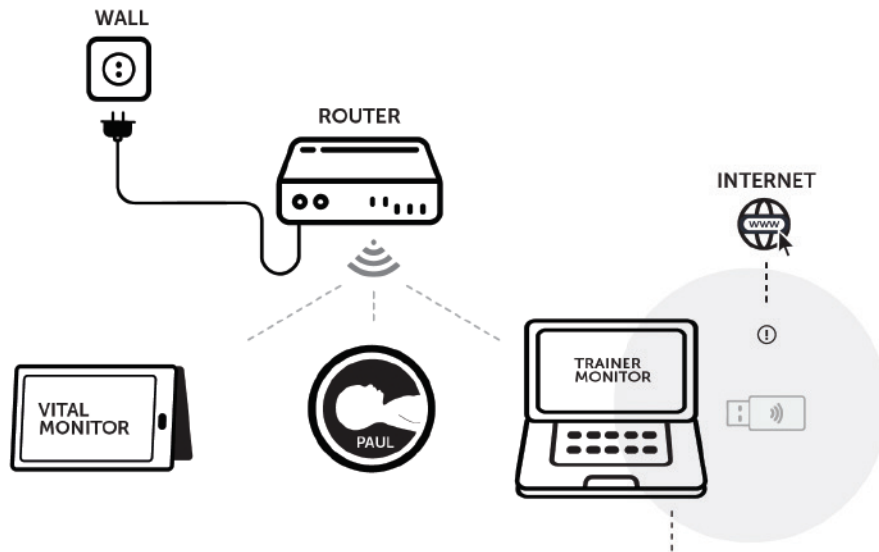

TROUBLESHOOTING

If the router, Paul, the trainer laptop and the patient monitor are started as described in the „**System setup**“ section, all components should be in the same network and automatically connect to each other.

While the connection between the individual components is being established, this process can be recognised by the „**Connecting**“ message in the status window. Problems with the connection will be displayed in this window and you will also be offered direct solutions.



IF ONE OF THE COMPONENTS DOES NOT CONNECT:

1. Please check whether the WLAN router is switched on and the power light on the back is flashing.
2. Please check whether the trainer laptop is in the correct „Paul Network“ network.
3. Please check whether the Vitalmonitor is in the correct „Paul Network“ network.
4. Please check that the stethoscope is switched on.

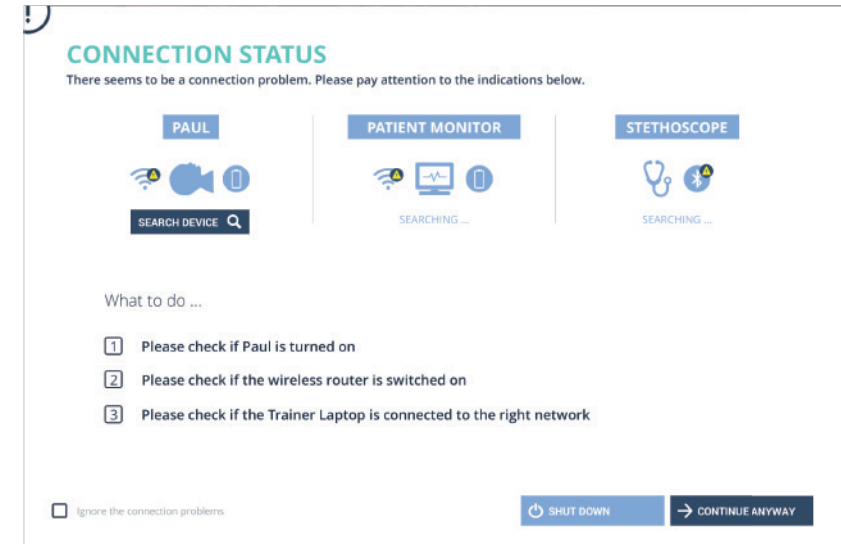

IF THE SYSTEM IS STILL NOT WORKING CORRECTLY:

Please switch off all individual devices.

If Paul does not connect or cannot be switched off using the turn-off button on the user interface, please switch him off completely using the magnet provided. To do this, swipe the magnet over Paul's head several times in the area of the large fontanel. You will recognise that Paul is switching off by the initially red flashing light under Paul's belly skin, which then finally goes out.

Now switch all devices back on in the following order:

1. please plug in the router (and wait about 1 minute)
2. now switch on the laptop and the tablet
3. click on the SIMCharacters icons on both devices to start the software
4. now connect Paul to the charging cable (please wait until Paul breathes)
5. and then switch on the stethoscope.

OUR SUPPORT TEAM IS HERE TO HELP YOU

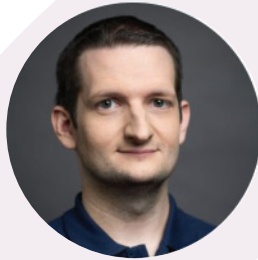

Michael Haller, MSc
HEAD OF RESEARCH & DEVELOPMENT



Arjeta Fishta
TECHNICAL SUPPORT



Bernhard Ehn
TECHNICAL SUPPORT



Ursula Holzschuh
LOGISTICS



Dr. Jens-Chr. Schwindt
FOUNDER & CEO

TECHNICAL SUPPORT

HOW TO CONTACT US

Phone or WhatsApp: + 43 664 25 66 818
Mail: support@simcharacters.com
General inquiries: info@simcharacters.com

SPECIFICATIONS PAUL 2.0

PAUL

- Length: 35cm
- Weight: 1100g
- Head circumference: 26cm
- Width (at the shoulders): 10cm
- Abdominal circumference: 23 cm
- Operating temperature: 0 to +30° C

AKKU

- Manufacturer: SIMCharacters GmbH
- Type: PHE02.BAT.00
- Technology: Li-Ion
- Voltage: 7,4 V
- Capacity: 1750 mAh
- Measurements: (B/D/H): 55 × 36 × 30 mm
- Operating temperature: 0 to +45° C
- Storage temperature: -20 to +60° C

PAUL RADIO MODULE

- Laird Sterling™-LWB5+
- WiFi: 2.4 & 5 GHz, a/b/g/n/ac
- Bluetooth: 5.2 - FCC Nr.: SQG-LWB5PLUS
- FCC ID: SQG-LWB5PLUS
- IC Nr.: 1000X-ND1
- Japan (MIC): 201-200402
- Canada (ISED): 3147A-LWB5PLUS

CHARGING PAD

- SCHOETECH T535-S
- Qi Certified Wireless Charger
- UL Listing ID: E473321

WIFI ACCESS POINT

- Mikrotik hAP ac² - RBD52G-5HacD2HnD-TC
- FCC Nr.: TV7RBD52-5ACD2ND
- Operating temperature: -40°C to 50°C

CONTROL LAPTOP (TRAINER)

- Microsoft Surface Laptop Studio 2
- Operating system: Windows 11 Pro or Home 64bit
- Working memory: 16GB
- Hard disc storage: 256GB SSD

TABLET (PATIENT MONITOR)

- Microsoft Surface Pro 10
- Operating system: Windows 11 Pro or Home
- Working memory: 8 GB
- Hard disc storage: 256 GB SSD

TRANSPORT CASE

- Xtrem Mobil - 23
- Measurements: (B/D/H): 544 × 61 × 425 mm



In accordance with the requirements of the European Directive 2012/19/EC on waste electrical and electronic equipment (WEEE), this appliance is labelled. You will be making a positive contribution to the protection of the environment and human health if you dispose of this appliance in a separate waste collection. In unsorted municipal waste, improper disposal of such an appliance could have negative consequences.



The following symbol of a crossed-out wheelie bin is shown on the product. It indicates that disposal in normal household waste is not permitted.

Please contact the manufacturer, the sales partner from whom you purchased this appliance, your local authority or your local household waste recycling center for further information on the treatment, recovery and recycling of this product.

© SIMCharacters, September 2024.

All rights reserved. The text, images, graphics and their arrangement in this manual are protected by copyright and other protective laws.

The content of this manual may not be copied, distributed, modified or made accessible to third parties for commercial purposes.

SIMCharacters accepts no liability for the topicality, correctness, completeness or quality of the information provided.

Liability claims against SIMCharacters relating to material or immaterial damage caused by the use or non-use of the information provided or by the use of incorrect or incomplete information are fundamentally excluded, unless SIMCharacters can be proven to have acted with intent or gross negligence. All offers are subject to change and non-binding.

SIMCharacters expressly reserves the right to change, supplement or delete parts of the pages or the entire manual without prior notice or to cease publication temporarily or permanently. The copyright for published objects created by SIMCharacters itself remains solely with SIMCharacters.

Reproduction or use of such graphics and texts in other electronic or printed publications is not permitted without the express consent of SIMCharacters.



Contains IC: 3147A-LWB5PLUS
 Contains FCC ID: SQG-LWB5PLUS
 Contains KC ID: R-C-L7C-SterlingLWB5
 Contains MIC ID: 201-200402



SIMCharacters GmbH
 Lehárgasse 1/5
 1060 Vienna
 Austria



Model: **PHE02**
 Serial No: ###
 Input: 5 - 20V $\overline{=}$ 1,9A





SIMCharacters GmbH

Lehár-gasse 1/5, 1060 Vienna, Austria

www.simcharacters.com

EMAIL: info@simcharacters.com

PHONE: +43 1 581 20 94